

- 3-phase planetary gear motor with brake
- Control unit mounted on carriage
- Electrical connection 3~ 400V/50Hz
- Easy operation of control unit
- Easy adjustment of stop positions

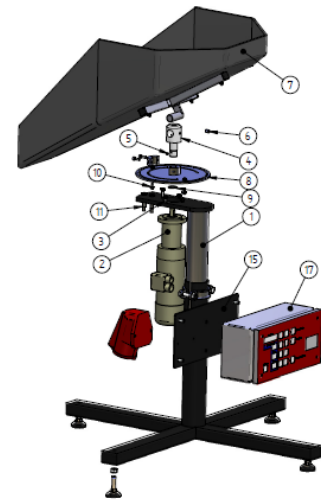

SPEZIFICATION*

Design	
Pivoting range	
Chute material	
No. of desired stop positions (default setting, max. 15)	

Socket for feeding conveyor	
Control unit	
3-color light beacon (only in combination with S7 control)	<input type="checkbox"/>
Wheel stand	<input type="checkbox"/>

Notes / Special requirements

* further options available on request