

### DRIVE UNIT\*

- Drive laterally, outlet left
- Belt Speed 4,6m/min
- Motor protection switch with ON/OFF switch
- Connection 3~ 400V/50Hz

### BELT\*

- PU-belt, teal, MTF-No. 14, FDA
- Temperature Resistance: -15°C to +90°C
- T-cleats, 30mm high, pitch 400mm

### CARRIAGE\*

- moveable

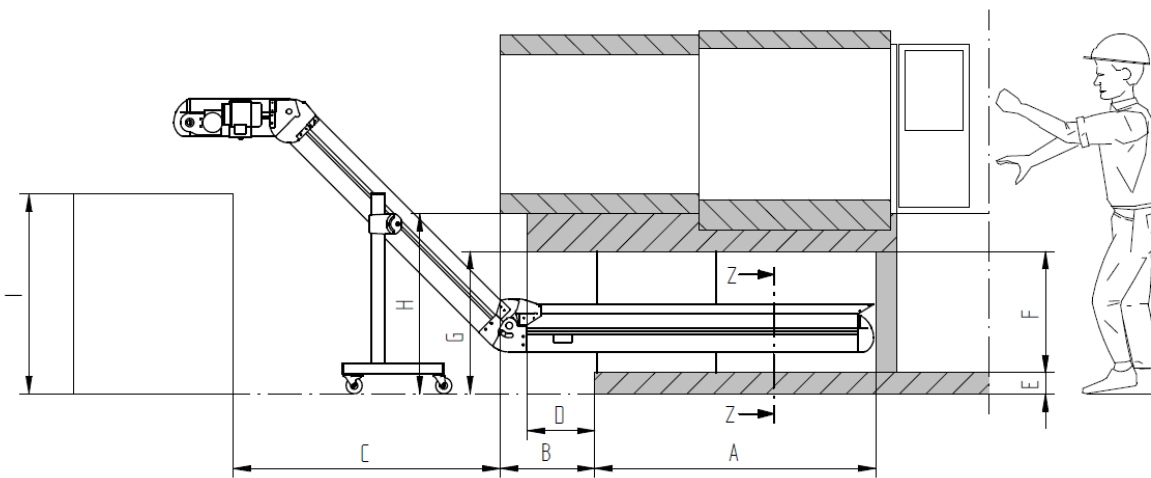
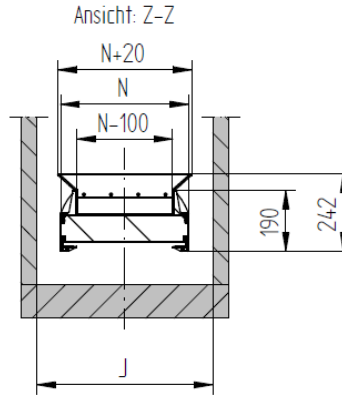

\* Sample configuration – other configurations available on request

N (mm)	...please choose...
A (mm)	
B (mm)	
C (mm)	
D (mm)	
E (mm)	
F (mm)	
G (mm)	
H (mm)	
I (mm)	
J (mm)	

### Goods to be conveyed

Description		
Parts per time unit [pcs./min.]		Biggest part L x W x H [mm]
Part temperature [°C]		Smallest part L x W x H [mm]
Max. part weight [g]		Max. load on conveyor [kg]

### OPTIONS\*\*

Frequency Inverter for continuously adjustable belt speed	<input type="checkbox"/>
Clock Timer for Start-/Stop operation via potential free contact or adjustable run- and pause-time	<input type="checkbox"/>
Carriage stationary	<input type="checkbox"/>
Corrugated edges (for small, sharp parts)	<input type="checkbox"/>
Conveyor covers	<input type="checkbox"/>
Sleivable outlet chute	<input type="checkbox"/>

Notes / Special requirements

\*\* further options available on request