

Operating instructions and spare parts list

Multi-Separator MSL/MSR Separation Attachment



Revision: 01

Translation of the original document
(contains optional variants)
09.01.2024

English (US) (Englisch)

EN-BE-AW-01



MTF Technik
Hardy Schürfeld GmbH & Co. KG
Stadionstraße 8
D-51702 Bergneustadt

Tel.: +49 (0) 2261/94 31-0
Fax: +49 (0) 2261/94 31-31
info@mtf-technik.de
www.mtf-technik.de

© 2024 MTF Technik Hardy Schürfeld GmbH & Co. KG. All rights reserved.

The copyright for this documentation remains with MTF Technik Hardy Schürfeld GmbH & Co. KG. The documentation contains information of a technical nature which may not be copied or distributed, neither in whole or in part, nor utilized or passed on to third parties for the purpose of competition without permission.

1	General	6
1.1	Use and storage	6
1.2	Information about the manufacturer and contact address	6
1.3	Symbols and abbreviations	7
1.4	Scope of application	8
1.5	Other applicable documents	9
1.6	Warranty	9
2	Safety	10
2.1	General safety information	10
2.2	Compliance with the instructions for use	10
2.3	Intended use	11
2.4	Improper use	12
2.5	Foreseeable misuse	12
2.6	Warnings in the instruction manual	13
2.7	Safety and warning signs on the machine	14
2.8	Operating requirements	14
2.9	Safety devices and guards	14
2.10	Duties of the operator	15
2.10.1	General requirements	15
2.10.2	Operating instructions	15
2.10.3	Local statutory regulations	15
2.10.4	Personnel requirements	16
2.10.5	Conversions and unauthorized modifications	16
2.10.6	Testing	16
2.10.7	Cleaning, maintenance, repair and overhaul	17
2.10.8	Briefing	17
2.11	Qualification of the personnel	18
2.12	Safety instructions for the personnel	19
2.12.1	Operation of the system	20
2.12.2	Personal protective equipment	21
2.13	Transport and installation	21
2.14	Safety checks	22
2.15	Notes concerning specific hazards and residual risks	22
2.15.1	Hazards caused by untrained personnel	22
2.15.2	Hazards caused by electrical energy	23
2.15.3	Hazards caused by compressed air	23
2.15.4	Hazards caused by hot spots	24
2.15.5	Hazards when handling chemical substances	24
2.15.6	Hazards caused by moving components	24
2.15.7	Hazards caused by environmental conditions	25
2.15.8	Hazards for the environment	25
2.16	Spare parts and wear parts	26
2.17	Procedures in the event of an emergency	26
2.18	Procedures in the event of malfunctions	27
3	Technical data	28
3.1	Technical data	28

3.1.1	Type plate	29
4	Layout and function.....	30
4.1	Brief description	30
4.2	Overview	31
4.3	Functional description	32
4.3.1	General overview figures	32
4.3.2	Operating mode	35
4.4	Connections	36
4.4.1	Electrical connection	36
4.5	Displays and operating elements	37
4.5.1	Mains switch	37
4.5.2	Speed adjuster	37
4.6	Modes of operation	38
4.6.1	Normal operation	38
4.7	Accessories and tools	38
4.7.1	Accessories	38
4.7.2	Tools	38
5	Packaging and transport.....	39
5.1	Safety	39
5.2	Check of the delivery	41
5.3	Unloading, transport into a building, setting-down	41
5.4	Unpacking	41
6	Installation and first start-up.....	42
6.1	Installation: General note	42
6.2	Safety	42
6.3	First start-up	44
6.4	Setting the separating parameters	45
6.4.1	Setting the separating gap	45
6.4.2	Setting the gradient, height and alignment	46
6.5	Start-up after a planned shutdown	48
7	Operation.....	49
7.1	Safety	49
7.2	Prior to operation	50
7.3	Operating and display elements	51
7.4	Switching the machine on	51
7.5	Operating modes	52
7.6	Switching the system off	52
8	Maintenance.....	52
8.1	Safety	52
8.2	Maintenance instructions	54
8.3	Preparation for maintenance	55
8.4	Maintenance plan	56
8.5	Switching back on after maintenance	57
9	Troubleshooting	58
9.1	Safety	58

9.2	Procedures in the event of malfunctions	59
9.3	Preparations for troubleshooting	59
9.4	Restart after a malfunction	59
9.5	Troubleshooting	60
10	Disassembly.....	61
10.1	Safety	61
10.2	Prerequisites for the disassembly	63
10.3	Disassembly of the electrical system	63
10.4	Disassembly of the mechanical system	63
11	Disposal.....	64
11.1	General notes.....	64
12	Spare parts	65
12.1	Viewing the spare parts list	65
12.2	Exploded drawing.....	66
12.3	Spare parts list, worm separator	67
12.4	Spare parts list, worm roller	69
12.5	Spare parts list, MSL/MSR support.....	71
12.6	Spare parts list SAL/SAR mounting frame.....	72
13	Keywords index	73
14	List of figures	74
15	List of tables.....	74
16	Appendix	75

1 General

1.1 Use and storage

Compliance with the following points is mandatory:

- These operating instructions are indispensable for the safe start-up, operation, and maintenance of the unit/machine in line with its intended purpose.
- These operating instructions apply solely to the product that is stated on the cover sheet.
- We reserve the right to change these operating instructions due to further technical developments.
- These operating instructions are part of the scope of supply.
- These operating instructions apply from the transport phase up to final disposal and must be observed.
- Maintain these operating instructions in a clearly legible state and keep them readily available to the operating personnel near the unit/machine. Hand over the document along with the machine if it is resold.
- These operating instructions are intended solely for briefed and authorized personnel with the necessary qualifications.
- The operator must ensure that all of the persons involved read and understand the operating instructions prior to commencing their work.
- The “Safety” chapter provides an overview of all of the important safety aspects in order to ensure the optimum protection of the operating personnel and the safe and trouble-free operation of the system.
- The manufacturer accepts no liability for damage resulting from non-compliance with these operating instructions.
- Substances that are harmful to the environment or hazardous to health must be correctly and separately disposed of.
- Reprints, translations or reproductions in any form, either entirely or in parts, are not permissible unless authorized in writing by the publisher.
- The copyright is held by the manufacturer.

1.2 Information about the manufacturer and contact address

MTF Technik
Hardy Schürfeld GmbH & Co. KG
Stadionstraße 8
51702 Bergneustadt

Tel.: +49 2261 9431-0
Fax: +49 2261 9431-31
E-mail: info@mtf-technik.de
Web: www.mtf-technik.de

1.3 Symbols and abbreviations

The following is a list of the most important abbreviations used in these operating instructions.

Abbreviation	Designation
Fig.	Figure
BA	Operating instructions
EC	European Community
EU	European Union
EEA	European Economic Area
IP	Ingress protection
Pos.	Position number
ProdSV	Ordinance to the Product Safety Law (Machine Directive)
pcs.	Pieces
Tab.	Table
VDE	Verband der Elektrotechnik Elektronik Informationstechnik e.V. (Association of Electrical Engineering, Electronics and Information Technology)

Tab. 1: Abbreviations

The following is a list of the most important units used in these operating instructions.

Unit	Designation	Physical quantity
°C	Degree Celsius	Temperature
rpm	Revolutions per minute	Speed
A	Ampere	Magnitude of the electric current
kW	Kilowatt	Power
mm	Millimeter	Length
Pa	Pascal	Pressure
V	Volt	Electrical voltage

Tab. 2: Units

The following elements form parts of these operating instructions:

Numbered lists in handling instructions:

1. Step 1
2. Step 2
3. ...

Numbering in figures and legends:

- 1 Component 1
- 2 Component 2
- 3 ...

Bullet point list for information without a particular sequence:

- Information
 - Sub-item
 - Sub-item
 - ...
- Information
- ...

NOTE



- The signal word **Note** marks additional information concerning the machine or its accessories.
- See the chapter **Depiction of Warning Instructions** for further signal words and symbols.



Internal reference:

This is used to mark references within the document leading to additional information.



External reference:

This is used to mark references to external documents in which additional information can be found.



Disposal of used electrical and electronic devices

The symbol on the product or packaging indicates that this product should not be treated as normal household waste. Instead, it must be handed over to a reception point for the recycling of electrical and electronic devices. Further information can be obtained from your local council, local waste disposal operators, or specialized traders.

1.4 Scope of application

- The product complies with the directives of the European Union.
- Please observe:
 - the enclosed CE declaration of conformity,
 - the information about the intended use and
 - the information about any improper use which is not in line with the intended purpose.

1.5 Other applicable documents

These further applicable documents are relevant for the utilization of this product and these operating instructions:

- CE declaration of conformity
- General terms and conditions, including warranty information
- Drawings
- Sound measurement report
- Information about accessories
- Documentation provided by third-party manufacturers
- Electrical documentation
- Safety data sheets
- Project drawings

1.6 Warranty

Warranty claims must be submitted to the manufacturer immediately after a defect or fault has been detected.

- The warranty becomes null and void in all cases in which liability claims cannot be enforced.
- The information, data and notes included in these operating instructions were up to date at the time of printing.
- No claims for the modification of systems and components that have already been supplied may be made on the basis of the information, illustrations and descriptions in these operating instructions.
- The information in these operating instructions describes the characteristics of the product without guaranteeing them.
- No liability will be accepted for damage and malfunctions resulting from:
 - Failure to observe the operating instructions
 - Unauthorized modifications to the system
 - Operating errors
 - Failure to perform the specified maintenance tasks

2 Safety

2.1 General safety information

The "Safety" chapter provides an overview of all of the important safety aspects for the optimum protection of the personnel and for the safe and trouble-free utilization of the machine from the transport phase and system operation up to its disposal.

Non-compliance with the instructions and safety notes in these instructions for use may lead to substantial hazards to persons and damage to the machine.

The machine has been designed and manufactured in line with the state of the art and the recognized safety regulations and standards. The machine is safe to operate.

The machine may present residual risks if

- the machine is not used in line with its intended use.
- the machine is operated improperly by untrained or uninstructed personnel.
- the machine is repaired or maintained improperly.
- the safety instructions and warnings that are stated in this instruction manual are not adhered to.
- the machine is modified or converted improperly.
- the prescribed maintenance tasks are not performed in due time.

2.2 Compliance with the instructions for use

NOTE



Any person who is ordered to work on or with the machine must have read and understood these operating instructions, in particular, the "Safety" chapter.

Knowledge of, and compliance with, the content of these instructions is absolutely necessary for the protection of persons against hazards and for avoiding machine faults.

- This is why compliance with all of the safety instructions is mandatory in the interest of your own safety.
- The operating instructions are an integral component of the machine and must be available at the machine at all times. The personnel must read, understand and follow the operating instructions when performing any tasks.
- Please contact the manufacturer without delay (see the chapter "**Information about the manufacturer and contact address**", page 6) if any questions are left open or if parts of these operating instructions are unclear.
- Apart from the safety instructions in this manual, compliance with the following rules and regulations is also mandatory:
 - Intended use
 - The relevant accident prevention regulations
 - Occupational health regulations
 - Generally recognized safety rules
 - Country-specific provisions
 - The documentation concerning any attachments or attachments
 - The documentation provided by third-party manufacturers that is supplied with the machine
 - The information (safety data sheets) provided by the various manufacturers and suppliers of process materials (oils and greases), auxiliary materials, and chemical substances

These rules and regulations can additionally be complemented by specific operating procedures to cover any intra-plant provisions or special operating features.

As a complement to these operating instructions, intra-company briefing must be provided, taking into consideration the professional qualification of the persons attending this briefing.

The product-accompanying documentation provided by MTF Technik does not invalidate the safety regulations of the operator of the overall system, which instead take precedence.

2.3 Intended use

The machine is intended solely for the following uses:

- The worm separator is used to separate parts with different dimensions, for example injection moldings and their sprues. It can also be used to separate and thus count parts.

The parts to be separated fall on to the slide sheet in the inlet area and then slide against the separating worm roller as a result of the adjustable gradient. The roller is mounted relative to the slide sheet at a height matched to the material to be separated. Consequently a defined gap is created between the roller and slide sheet through which only parts with an appropriate height can pass. Larger parts are conveyed sideways by the helical web on the roller and at the end of the roller fall down sideways from the slide sheet. The parts sliding under the roller fall down at the bottom end of the slide sheet.

The separated from each other, falling parts are collected in/on suitable boxes, conveyor systems (e.g. conveyor belts) or further processing systems.

- The worm separator is intended solely for **commercial use** and not for domestic and private use.

All of the products of MTF Technik as well as all of the other parts that are included in the scope of supply of MTF Technik are intended solely for the purpose that is described in this manual in combination with the technical specification. The technical specification is part of the contract. In particular, the technical data and the provisions concerning the permissible use (assembly, connection, ambient conditions and operating conditions) shall apply. They can be found on the type plate and in the further applicable documents (order documents).

The intended use also includes compliance with the operating instructions and the fulfillment of the inspection and maintenance conditions.

The product-specific documentation can only refer to the intended use of the machine on which the order is based. The operating instructions cannot cover any specific situations arising from special local conditions or special applications that the manufacturer was not aware of. In this case, the operator must ensure the safe operation of the machine or shut the machine down until appropriate measures for the safe operation have been coordinated or implemented in consultation with the manufacturer or other competent authorities.

2.4 Improper use

Any use other than the one described in the chapter "Intended use" and in these operating instructions, and any use going beyond these stipulations, shall be considered as improper use.

The machine is **NOT** intended for the following uses:

- Modifying the machine in any way is strictly prohibited.
- Using the machine if the safety devices and guards have been bypassed or disabled is strictly prohibited.
- Using the machine for the transport of persons is strictly prohibited.
- Transporting loads or materials other than the ones specified in this instruction manual is strictly prohibited.
- Using the machine in potentially explosive atmospheres is strictly prohibited.
- Using the machine in areas which may be subject to the ingress of water of any type (rain, splash water, flooding, etc.) is strictly prohibited.

The following fundamental rules apply at all times:

Any use other than the intended use is an improper use.

The manufacturer cannot be held liable for any resulting damage. The risk for such use shall be borne solely by the user/operator.

Moreover, the use of the device in compliance with applicable international and national safety instructions, and in compliance with the safety instructions in the operating instructions is classed as intended use.

2.5 Foreseeable misuse

The following points describe a foreseeable misuse of the system:

- Set-up on unsuitable surfaces
- Attachment of transport equipment to the housing
- Non-compliance with the operating data
- Non-compliance with the maintenance intervals
- Switching on during rundown of the machine
- Operation without (or with damaged) components that ensure the safety of persons and the machine

2.6 Warnings in the instruction manual

Warning notes are marked by a signal word panel in this instruction manual. The warning notes are preceded by signal words indicating the severity of the hazard. Compliance with the warning notes is imperative in order to avoid accidents, injuries and damage to property.

The following keywords and symbols are used in this instruction manual:



This is the general hazard symbol. It warns of life-threatening dangers.

Measures that are marked with this symbol indicate a danger to persons. Compliance with these warning notes is mandatory in order to avoid injuries or death.

DANGER

Death or serious injuries *will result* if the corresponding safety precautions are not taken.

WARNING

Death or serious injuries *may result* if the corresponding safety precautions are not taken.

CAUTION

This keyword indicates a potentially hazardous situation that may result in **minor injuries** if it is not avoided.

ATTENTION

This keyword indicates a potentially hazardous situation that may result in **damage to property** if it is not avoided.

2.7 Safety and warning signs on the machine

Any notes or symbols that are affixed to the machine, e.g. safety labels or signs, must be complied with. Do not remove them and ensure that they are legible at all times.

2.8 Operating requirements

As the manufacturer, MTF Technik has no information about any possible interdependence with other systems and devices. This has to be reviewed separately by the operator.

Furthermore, the following conditions must be fulfilled for the normal operation of the machine if they are not part of our area of responsibility:

- Assembly completed as specified.
- Successful test run, including all of the necessary adjustments.
- Briefing of the operating personnel concerning the operation of the machine and the relevant safety regulations.
- If hazards are caused by hot or cold machine parts, these machine parts must be provided with guards to prevent contact.
- Exclusion of hazards caused by electrical energy (see the relevant VDE regulations or the regulations of the utility companies for details).
- Easy access to the machine must be guaranteed.
- Appointment of a person who shall be responsible for the proper operation of the machine.

2.9 Safety devices and guards

There is an increased risk of injury if the safety devices and guards are damaged, modified, removed or disabled. Do not use the machine unless it is fully equipped with all of the protective devices and safety devices and guards.

- Ensure that the safety devices and guards are absolutely fault-free and in perfect working condition.
- The protective devices, safety devices and guards must not be removed, disabled or modified. This also applies to test runs.

NOTE



- Qualified personnel, must check for the trouble-free functioning of the safety equipment, especially after maintenance, repair or overhaul.
- If the machine must be run temporarily without a safety device during maintenance, repair or overhaul, it must be absolutely ensured that no persons are present in the cordoned-off hazard area.

The responsible person (shift supervisor, foreman, etc.) must be informed immediately of any faults concerning the safety devices and guards.

The machine is equipped with the following safety devices and guards:

- Mechanical protection and covers
- Emergency-STOP push-button (can be implemented using the mains switch).

2.10 Duties of the operator

2.10.1 General requirements

The machine must be operated in such a way that it reliably fulfills all of the requirements concerning its intended use and the expected load. The machine must be inspected by a qualified and competent person prior to its initial start-up and also after any type of maintenance, repair, overhaul or structural modification.

2.10.2 Operating instructions

The operating instructions are an integral part of the system. The operator must ensure that the operating instructions are read by every person working on or with the machine. The operating instructions must be accessible at the location of use of the machine at all times.

MTF Technik shall not accept any liability for damage resulting from non-compliance with the product-accompanying documentation.

The operator is required to complement the operating instructions with specific operating procedures in line with the applicable local regulations. Next to the regulations specified hereinafter, this also includes information about the supervisory responsibilities and reporting obligations. The aim is to take into consideration any operational peculiarities concerning the organization of work, the workflow and the appointed personnel.

2.10.3 Local statutory regulations

The operator is responsible for compliance with the binding laws, provisions and decrees and with the existing national regulations concerning the prevention of accidents and with any internal work, operating or safety instructions that are valid at the location of use of the machine.

The following points are part of the applicable local regulations and laws:

- Safety of personnel (accident prevention regulations)
- Safety of work equipment (protective equipment and maintenance)
- Product and material disposal (Waste Management Act)
- Cleaning (cleaning agents and disposal)
- Environmental protection requirements

The operator must ensure that the following tests are performed:

- Test of the machine in terms of its operational safety
- Functional test of the safety devices and guards
- All of the tests that are specified in the maintenance plan

2.10.4 Personnel requirements

The operator must ensure that the following conditions are fulfilled:

- Only trained personnel who are familiar with the fundamental occupational health and safety regulations and who have been instructed in the handling of the machine must be deployed.
- Compliance with the legal minimum age limit.
- Only personnel who have been charged by the operator to do so, are authorized to operate, maintain, repair, and overhaul the machine.
- The area of responsibility, scope of competence and supervision of the personnel must be clearly defined and specified by the operator in order to avoid any ambiguities concerning these points.
- No access to the area of the system for unauthorized persons.
- Compliance with the supervisory responsibilities and reporting obligations as well as with any operational peculiarities.
- Explanation of instructions governing the correct procedures in the event of an emergency. Among other things, knowledge of first-aid measures and the local emergency facilities must be ensured.
- Explanations concerning the handling of hazardous substances.

NOTE

▶ The responsibility for the accident-free operation of the machine lies with the operator or with the personnel authorized by the operator. If the personnel lack the necessary knowledge, corresponding training and instruction must be provided.

2.10.5 Conversions and unauthorized modifications

Any additions or conversions to/of the machine by the operator must be checked for any significant changes. If the change in question is significant, the issued CE declaration of conformity is no longer valid and the operator legally becomes the machine manufacturer. In this respect, please see the machinery directive 2006/42/EC (EEA, Switzerland and Turkey) as well as the machine directive (9th ProdSV, Germany) and, as necessary, national laws and guidelines.

In addition, welding work on load bearing components is not permitted.

2.10.6 Testing

The operator must not start the machine unless a qualified and competent person has performed a test of the machine. This applies to the first start-up of the machine and also to the start of the machine after maintenance, repairs, overhauls or structural modifications.

Based on self-imposed or locally specified regulations, the operator must have the system checked in terms of its operational safety at regular, specified intervals by a qualified and competent person. The results must be recorded in a test log.

2.10.7 Cleaning, maintenance, repair and overhaul

The operator must ensure that the machine and safety devices and guards are kept in a functional state. The control devices as well as the safety devices and guards must be checked in terms of their effectiveness.

Only specialized and trained personnel are authorized to perform maintenance, repairs and overhauls.

The maintenance, repair and overhaul requirements are described in the instructions for use.

2.10.8 Briefing

The operator must protect personnel against any accidents and health hazards and instruct the personnel accordingly before the first performance of a task.

NOTE



The briefing must be repeated at specified intervals (at least once yearly).

- The personnel must read the operating instructions.
- The personnel must attend the briefing.
- The personnel must confirm awareness of the content through their signature.

2.11 Qualification of the personnel

Any work on the machine must be performed by qualified and instructed personnel and strictly in line with the existing rules and statutory regulations. The following points must be fulfilled:

- The personnel must have special knowledge and experience in the respective field of specialization. This applies, in particular, to overhauls and repairs of the electrical, mechanical, hydraulic and pneumatic systems of the machine.
- The personnel must have knowledge of the relevant standards, provisions, accident prevention regulations and operating conditions.
- The personnel must be appointed to perform the required tasks by the person responsible for safety.
- The personnel must be able to identify and avoid any potential hazards.

Depending on the location of use, the necessary qualification of the personnel may be subject to varying statutory provisions. The operator must ensure compliance with the relevant laws. Unless regulated by law, the following list is used to define the permissible personnel and their minimum qualification.

Persons	Task	Qualification	Phase (life cycle)
Qualified personnel for transporting loads	Lifting/lowering and transport of the system	Proven experience in the handling of suspended loads and in the securing of loads ¹⁾	Transport, assembly, disassembly and removal
Qualified personnel (mechanics)	Mechanical work during: installation, start-up, elimination of faults and malfunctions, maintenance and shutdown	Training as an industrial mechanic or an equivalent professional qualification (in-house training and/or external training) ¹⁾	Installation, start-up, elimination of faults and malfunctions, maintenance, shutdown, disassembly and removal
Qualified personnel (trained electricians)	Electrical work	Specialized electrical training or an equivalent professional qualification (in-house training and/or external training) ¹⁾	Installation, start-up, elimination of faults and malfunctions, maintenance, shutdown, disassembly and removal
Qualified personnel (machine operators and fitters)	Operation and set-up of the system	Person who has been trained and instructed by the operator based on the operating instructions	Start-up, operation, elimination of faults and malfunctions
Qualified personnel (disposal specialists)	Proper disposal of the system	Knowledge about the disposal regulations applicable on site	Shutdown, disassembly and removal, disposal
Qualified personnel (safety specialists)	Implementation of the applicable safety regulations	Knowledge about the safety regulations applicable on site	All phases
Visitors	Site inspection	Person under the supervision of a safety specialist	–

Tab. 3: Qualification of the personnel

¹⁾ Minimum of 3 years of work experience

2.12 Safety instructions for the personnel

Avoid any working practice that:

- puts the health and safety of the user or third parties at risk.
- is detrimental to the machine or other material assets.
- impairs the safety or functionality of the machine.
- does not comply with the safety instructions.

In addition:

- Do not perform any work on running machines.
- Do not perform any work on machine parts under electric voltage.
- Always wear personal protective equipment when working on the machine.

There is a risk of injury if the safety devices and guards are disabled. Never dismantle or disable any safety devices or guards.

- Check the safety devices and guards daily for correct operation.
- Report all the malfunctions and defects concerning the safety devices and guards to the operator without delay.
- Keep covers (e.g. panels, shields, housings) closed during operation.
- Observe the respective supplier's safety data sheets and disposal instructions as well as all of the local safety regulations when using chemicals.
- Wear protective clothing.
- Only perform tasks that you are familiar with, assigned to carry out and that belong to your working area.
- When handling process materials (e.g. oils, greases and other chemical substances), comply with the suppliers' specifications and safety information for the respective product.

There is a risk of damage to property if the machine is operated improperly.

- Comply with the description of any attachments or ancillary equipment (if included). See also the supplier documentation or the separate documentation provided by the third-party suppliers.

2.12.1 Operation of the system

- Operation is permissible only if all of the components are in a perfect technical state and proper operational condition and if they are used in line with the intended purpose.
- Avoid any operation that compromises the safety of the machine.
- The operator must ensure that unauthorized persons cannot work on the machine.
- Do not transport any persons with the machine.
- Prior to switching the machine on, the machine operator must ensure that no persons are put at risk by the start of the machine.
- During operation, the entire hazard area must be observed or closed off so that no one can enter this area without being noticed.
- Use the machine only if all of the guards and safety devices are present and fully functional.
- The machine operator must ensure a clean and clearly arranged workplace at and around the machine by issuing corresponding instructions and performing checks.
- The operating personnel must be briefed about the location and use of fire extinguishers. The fire detection and firefighting procedures must be observed.

2.12.2 Personal protective equipment

Failure to wear personal protective equipment may result in serious injuries or death.

- Wear the prescribed personal protective equipment, e.g. ear protection, eye protection, safety footwear, hard hats, protective clothing, safety gloves, and respiratory protective equipment, whenever working on the machine.



- Long hair must be tied back. Do not wear any loose-fitting clothes or jewelry. There is a risk of injury if these items get caught in or are pulled into any moving components of the machine.
- Ensure that no unauthorized persons are present in the hazard area.

2.13 Transport and installation

There is an increased risk of injury for persons who perform tasks for which they are neither qualified nor trained. Only appropriately trained persons should be entrusted with the fastening of loads and with acting as banksmen for the crane operators. Compliance with the accident prevention regulations is particularly important.

- The shipping company and MTF Technik must be informed immediately in writing about any damage that is noticed after the delivery. The start-up of the machine must be suspended, if necessary.
- Use only suitable lifting devices, transport equipment, load handling attachments and lifting accessories and ensure that they are in a perfect technical state and have a sufficient load-bearing capacity.
- Lift the machine or parts thereof only via the attachment points that are intended for this purpose.
- Check all of the suspension points, e.g. lifting eyes, prior to using them. This applies particularly to the later transport of the machine after a long period of utilization. suspension points that no longer correspond to the delivery state of the machine must not be used.
- Do not add any additional attachment points to the machine by welding, flame cutting or drilling. There is a risk of cracking due to the notch effect of the weld seam or flame-cutting spot or bore.
- Never work or stand under suspended loads. There is a risk of fatal injuries from falling loads.
- If parts of the system or large assemblies need to be replaced, fasten and secure them thoroughly on the lifting devices.
- The banksman must be within the range of vision of the operator or have voice contact with the operator.
- If parts of the system need to be disassembled for transport, they must be reinstalled and fastened properly prior to restarting the system.

2.14 Safety checks

There is an increased risk of injury for persons who perform tasks for which they are neither qualified nor trained.

- Only persons who are familiar with the tasks, who have been informed about the associated hazards and who have the necessary qualifications are authorized to start the machine.
- All technical safety conditions must be fulfilled prior to the start-up.

Safety checks to be performed for the start-up:

- Continuity check of the protective conductor system
- Functional check (check of the safety devices and guards, e.g. protective hoods)
- Insulation test
- Voltage test
- Protection against residual voltages
- Correct operation of the electrical equipment, particularly relating to the applicable safety and protection measures.

2.15 Notes concerning specific hazards and residual risks

The instructions and notes given here are to be considered as fundamental safety instructions and notes for specific types of hazards. These fundamental safety instructions must be observed during any type of work on the machine.

This is to prevent health hazards and dangerous situations. Special safety instructions and warnings are stated in the respective chapters and must also be observed.

Residual risks are determined by way of a risk assessment. Persons working on and with the machine must be informed about these residual risks. Intra-company briefing must be provided, taking into consideration the professional qualification of the persons attending this briefing. The instructions must be followed in order to avoid accidents or damage due to the residual risks.

2.15.1 Hazards caused by untrained personnel

Inexperienced and unqualified personnel put themselves and other persons at risk.

- Only persons who are familiar with the tasks that they are appointed to and who have been informed about the associated hazards are authorized to perform the tasks.
- The areas of responsibility of the personnel for the different life cycle phases must be clearly defined.
- Use only personnel who are sufficiently trained and authorized. The necessary qualifications are described in the personnel requirements.
- Personnel in training may work on the machine only under the permanent supervision of an experienced and qualified person.

2.15.2 Hazards caused by electrical energy

There is danger to life in the event of contact with live components. Serious injuries or even death may result. In addition, active electrical components may perform uncontrolled movements.

- Work on the electrical systems and operating equipment must be performed by qualified electricians and in accordance with the electrical engineering regulations. Prior to working on the electrical system:
 - Disconnect the machine from the power supply so that it is completely voltage-free.
 - Lock it so that it cannot be switched on again.
 - Ensure that the motors/drives and moving parts of the system are at a complete stop.
 - Close the working area off with a red-and-white barrier chain and mark the area with a warning sign.
 - Check whether the equipment is completely voltage-free.
 - Ground and short-circuit the equipment.
 - Cover any adjacent live parts.
- Only use insulated tools.
- Check the electrical equipment for signs of damage at regular intervals. Loose connections and scorched cables are a safety hazard. Eliminate any defects immediately.
- Keep the control cabinets closed at all times. Permit access only to authorized personnel.
- When working on live parts, always bring in a second person who can actuate the Emergency-STOP push-button or the mains switch to shut off the voltage supply in the event of an emergency. Immediately switch the machine off if there are malfunctions or faults concerning the energy supply.

2.15.3 Hazards caused by compressed air

Pressurized pneumatic components can cause severe injuries or even death.

- Only personnel with special knowledge and experience of pneumatic systems are allowed to work with pneumatic machines.
- Depressurize system sections and compressed air lines that are to be opened prior to beginning repair work. Do not open any pressurized air lines and do not tighten any compression couplings of lines under pressure. There is a risk of injury due to parts that may fly out.
- Correctly route and install the compressed air lines. Do not interchange the connections. The fittings, length and quality of the hose lines must fulfill the requirement.
- There is a risk injury and first if leaks occur. Regularly check all lines, hoses and fittings for leaks and externally apparent damage. Rectify any damage immediately.
- After cleaning the air lines, check them for leaks, loose connections, rubbing points and damage. Immediately rectify any identified defects.

2.15.4 Hazards caused by hot spots

There is a risk of burns due to the hot surface temperatures of motors and machine components.

- Keep a safe distance to hot components.

When working on or near hot spots of the machine:

- Wear suitable protective clothing.
- Switch parts of the machine off, if necessary.
- Let the components cool down.

2.15.5 Hazards when handling chemical substances

Contact with oils, greases and other auxiliary substances may cause chemical reactions.

- When handling chemical substances, observe and comply with the applicable regulations and safety data sheets of the suppliers.
- If there is contact with the skin or eyes, immediately rinse out the affected area with plenty of water. Suitable equipment (e.g. an eye wash bottle) must be available in the vicinity of the workplace.

2.15.6 Hazards caused by moving components

Moving machine parts that are freely accessible are dangerous spots that may lead to serious injuries or even death. There is an entanglement and crushing hazard caused by getting caught in or pulled into any moving components.

If the dangerous spots cannot be physically separated from the working area, the following safety measures must be taken:

- Maintain a safe distance from any moving parts.
- Wear tight-fitting clothes.
- Do not wear any rings, necklaces or other jewelry.
- In the case of long hair, wear a hairnet.
- Wait until the machine has stopped completely prior to performing any maintenance, repair or overhaul tasks. If necessary, depressurize the components.
- Lock the machine or parts of the machine so that they cannot be reactivated in order to prevent unintended movements of the machine parts. Close the working area off and mark it with a warning sign.

2.15.7 Hazards caused by environmental conditions

Insufficient lighting

Poor visibility due to insufficient lighting increases the risk of accidents.

- Ensure sufficient lighting prior to performing any tasks.

Insufficient access

Insufficient or unsafe access to the working area increases the risk of accidents, e.g. by falling.

- Access to hazard areas must be closed off by way of suitable measures.

Noise pollution

The noise level that could occur in the working area could increase the risk of accidents and harm the health of the personnel.

- When working with an increased noise level, wear effective ear protection.
- Only stay in the hazard area as long as this is absolutely necessary.

Contamination and soiling

The operation of the system leads to soiling, which presents a risk of slipping and injury to the personnel.

- Wear personal protective equipment and, in particular, safety shoes during all work.
- Eliminate any contamination and soiling immediately.

2.15.8 Hazards for the environment

Process materials, such as greases and oils, contain toxic substances that may contaminate the soil and groundwater. Process materials (grease, oil and other chemical substances) must not be released into the environment.

- Oils and greases must be disposed of in an environmentally sound manner.

The local disposal regulations must be observed.

- The disposal must be performed by a specialist disposal company.
- Observe the information provided by the suppliers and the safety data sheet of the substances.
- In addition, ensure to also observe the information in the supplier documentation.

2.16 Spare parts and wear parts

In the event of maintenance, repairs and overhauls, the operator must ensure that appropriate spare parts in compliance with the technical specifications of the manufacturer are used. This is ensured if original spare parts are used.

Spare parts and wear parts that are not supplied by MTF Technik have not been tested or approved. The installation or use of these components may have a negative effect on the specified design characteristics of the machine and thus compromise the safety of the machine.

MTF Technik shall not accept any liability for damage resulting from the use of non-original parts and accessories.

- Only use the original parts and original accessories that have been supplied by MTF Technik.
- We recommend keeping the most important spare parts and wear parts in stock on site.

2.17 Procedures in the event of an emergency

In the event of danger to life, the machine or parts thereof can be stopped by actuating an Emergency-STOP push-button (can also be implemented using the mains switch).

NOTE

▶ In the event that a separate Emergency-STOP push-button and a mains switch are present:

- An Emergency-STOP push-button should be actuated only in situations in which the safety of persons or of the machine is at risk.
- An Emergency-STOP push-button must not be used for switching the machine off in normal situations.
- An Emergency-STOP push-button does not disconnect the machine from the power supply.

After an emergency stop, authorized personnel must be brought in immediately in order to determine and eliminate the cause of the emergency.

An emergency stop of the machine interrupts the automatic process sequence. The machine must not be switched on again until the cause of the emergency stop has been eliminated.

To restart the affected part of the system, proceed as follows:

- Eliminate the hazard or malfunction.
- Unlock the Emergency-STOP push-button that has been pressed.
- If necessary, acknowledge the fault message via the control unit.
- Start machine operation.

2.18 Procedures in the event of malfunctions

Malfunctions of the machine may be caused by a single, simple fault that can be localized and eliminated.

- In the event of an imminent danger, immediately press the Emergency-STOP push-button (can also be implemented using the mains switch).
- Switch the machine off and lock it so that it cannot be switched on again. The machine must also be switched off in case of any unusual behavior of the machine. For example:
 - unusual noise, vibrations, smells,
 - faulty behavior and false indications,
 - high temperature.
- Disconnect the machine from the power supply so that it is completely voltage-free and authorize only trained and qualified personnel to eliminate the faults and malfunctions.
- If the malfunction cannot be eliminated, contact the service of MTF Technik.

3 Technical data

3.1 Technical data

Feature	Value
General technical data	
Product name	See the technical data in the product order confirmation!
Order confirmation no./ Pos.	
Separating lengths	
Ejection direction	
Material of the worm roller base body	
Power supply	
Electrical connection data	See the technical data in the product order confirmation!
Drive motor	
Electrical connection data	See the technical data in the product order confirmation!
Noise emission	
Emission sound pressure level at workstations	Dependent on the customer's mixed material being separated, the device is to be measured as part of a hazard assessment, even if it itself has no notable emissions.
Operating conditions	Normal operation at rated power
Environmental conditions	
Operating range	0 to +40°C
Humidity	5 - 85 %
Installation height above sea level	Max. 1000m
Ingress protection	IP54
Vibrations	Not applicable (2006/42/EC Machinery Directive)
Dimensions	
	See the technical data in the product order confirmation!

Tab. 4: Technical data

3.1.1 Type plate

The type plate is usually attached in the vicinity of the drive and contains information about the respective machine type and its technical details. Do NOT remove the type plate.

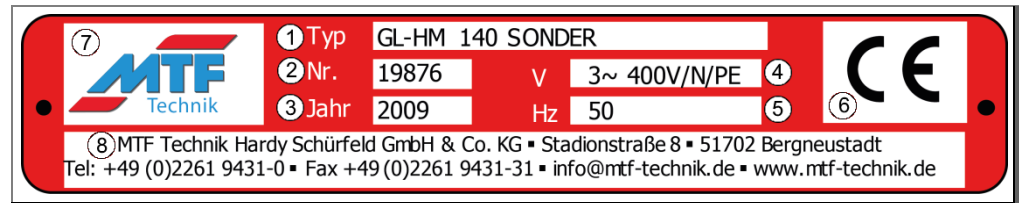

Fig. 1: Type plate (example)

No.	Description
1	Type designation
2	Serial no.
3	Year of manufacture
4	Supply voltage [V]
5	Connection frequency [Hz]
6	CE conformity marking
7	MTF Technik Logo
8	MTF Technik contact data

Tab. 5: Type plate descriptions

4 Layout and function

4.1 Brief description

The worm separator is for separating out separable mixed material (frequently bulk goods during production) based on their geometric dimensions. In doing so, larger parts (red arrow in the figure) are ejected sideways. Smaller parts (green arrow) slide through in the set gap below the worm roller. The lateral conveying movement of the worm (white arrow) is achieved by the rotation of the roller (yellow arrow) with attached helical webs.

Dependent on the requirement, the worm separator can be configured for a left or right ejection direction. In this case each separator is a mirror-image of the other. The left ejection direction is used by way of example in these instructions.

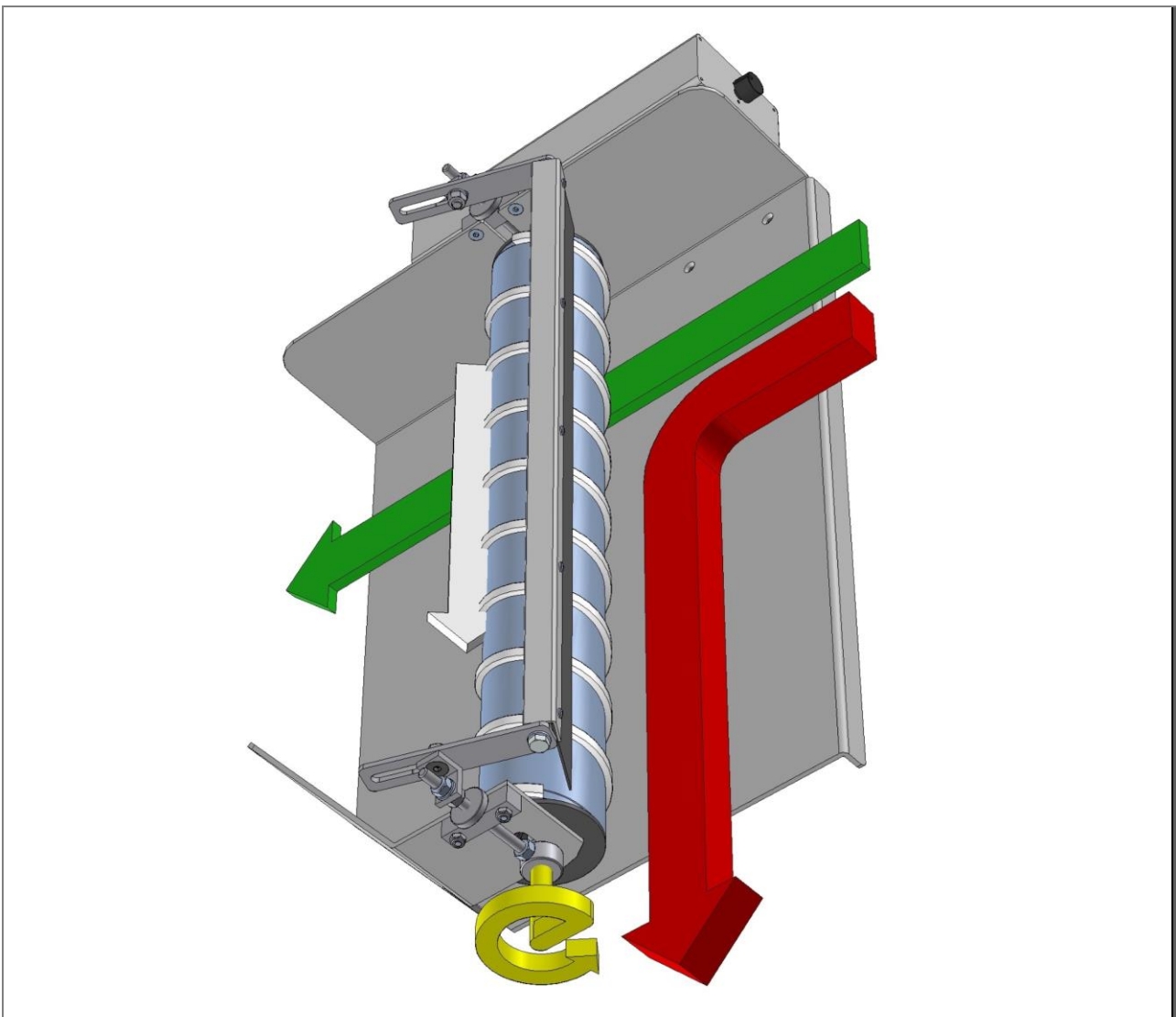

Fig. 2: Operating principle and part throughput direction, left ejection direction

4.2 Overview

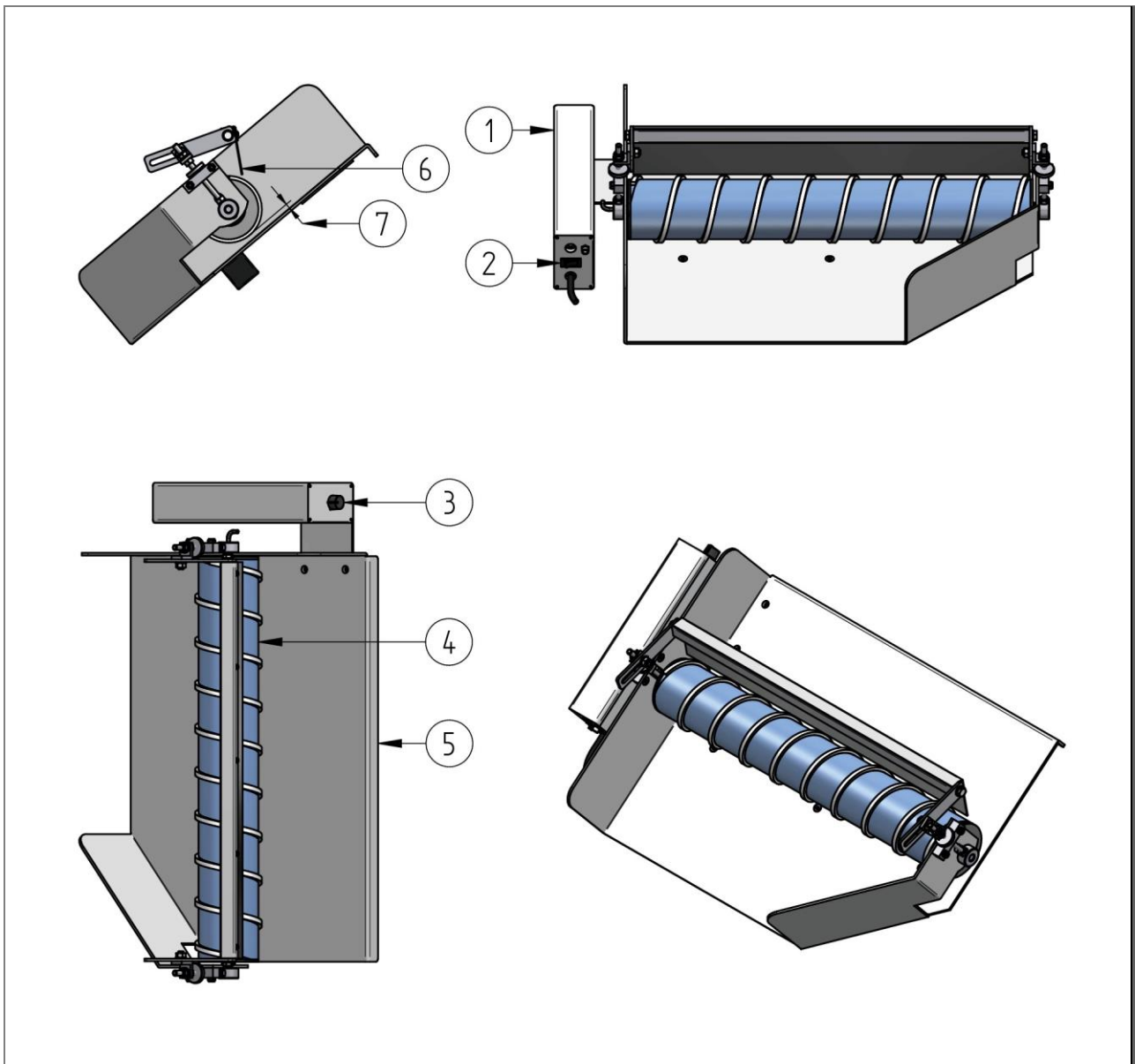

Fig. 3: Worm separator general overview

Item	Designation
1	Control unit
2	Mains switch
3	Speed adjuster
4	Worm roller
5	Slide sheet
6	Scraper
7	Separating gap (adjustable)

4.3 Functional description

4.3.1 General overview figures

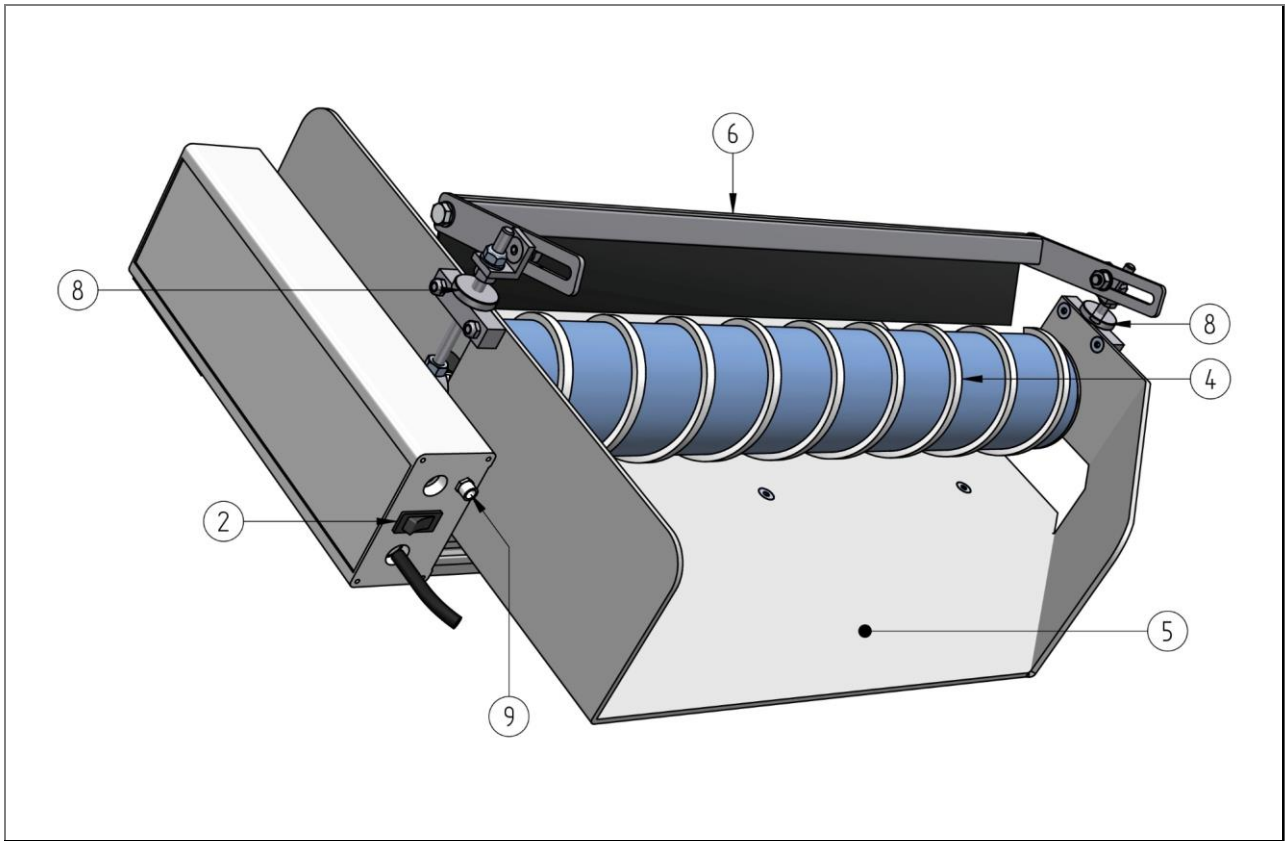

Fig. 4: Overview from the front

Item	Designation
2	Mains switch
4	Worm roller
5	Discharge sheet
6	Scraper (optional)
8	Knurled nut for adjustment of the separating gap
9	Connection means for external stop-start signal

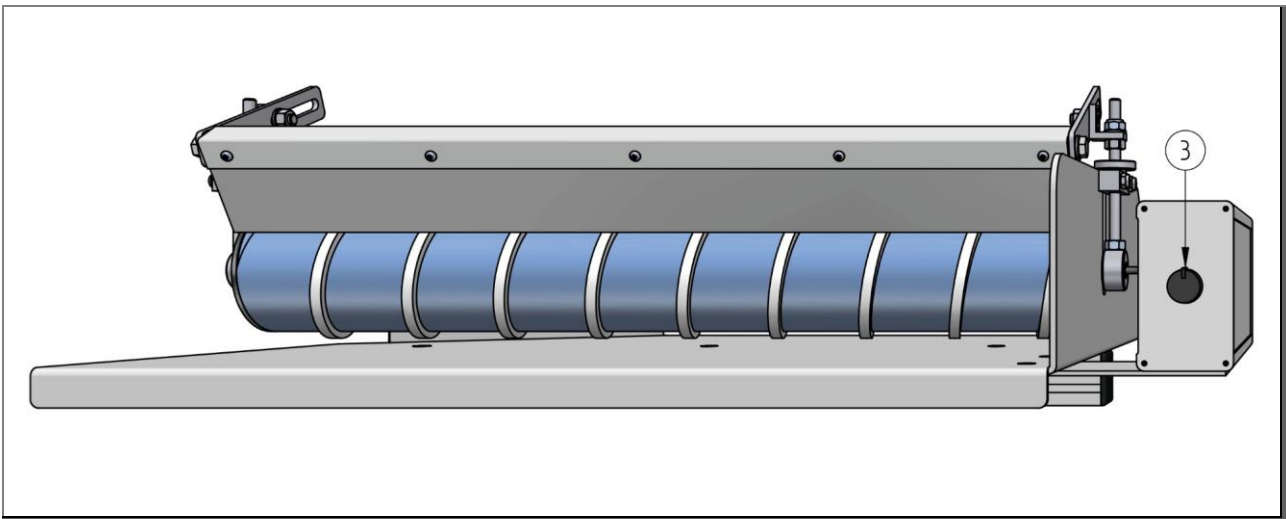

Fig. 5: Overview of the inlet side

Item	Designation
3	Speed adjuster

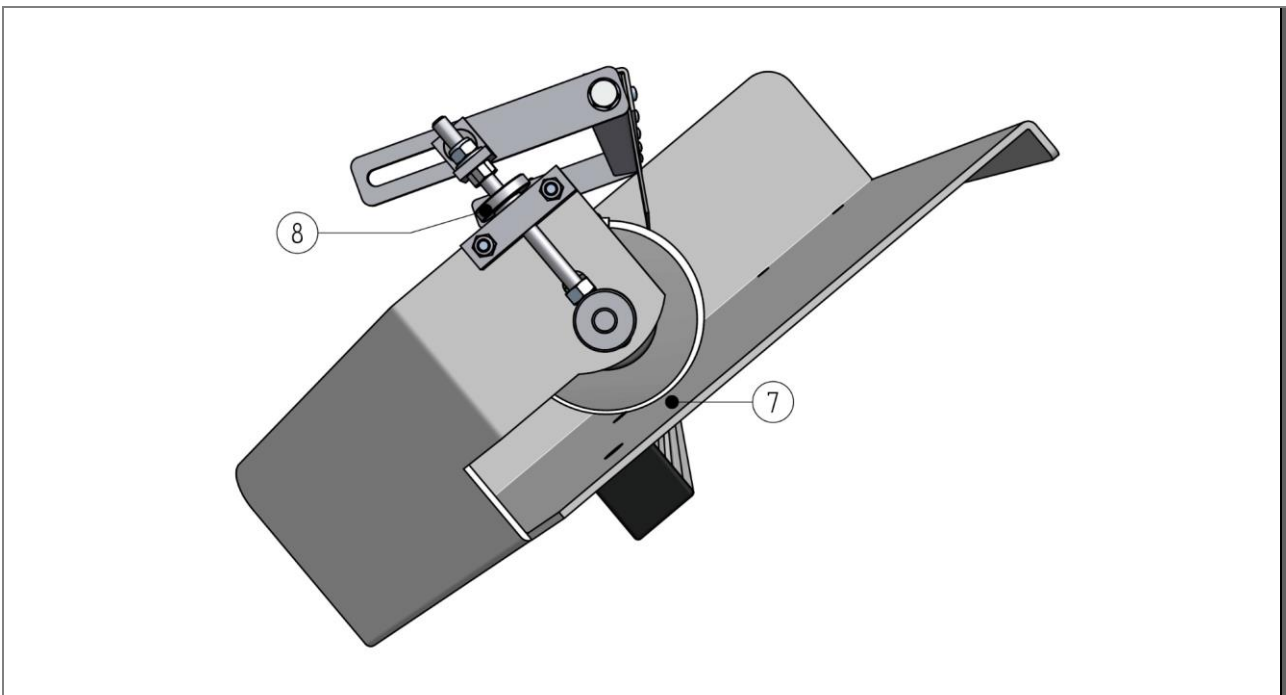

Fig. 6: Side view with separating gap

Item	Designation
7	Separating gap (adjustable)
8	Knurled nut for adjustment of the separating gap

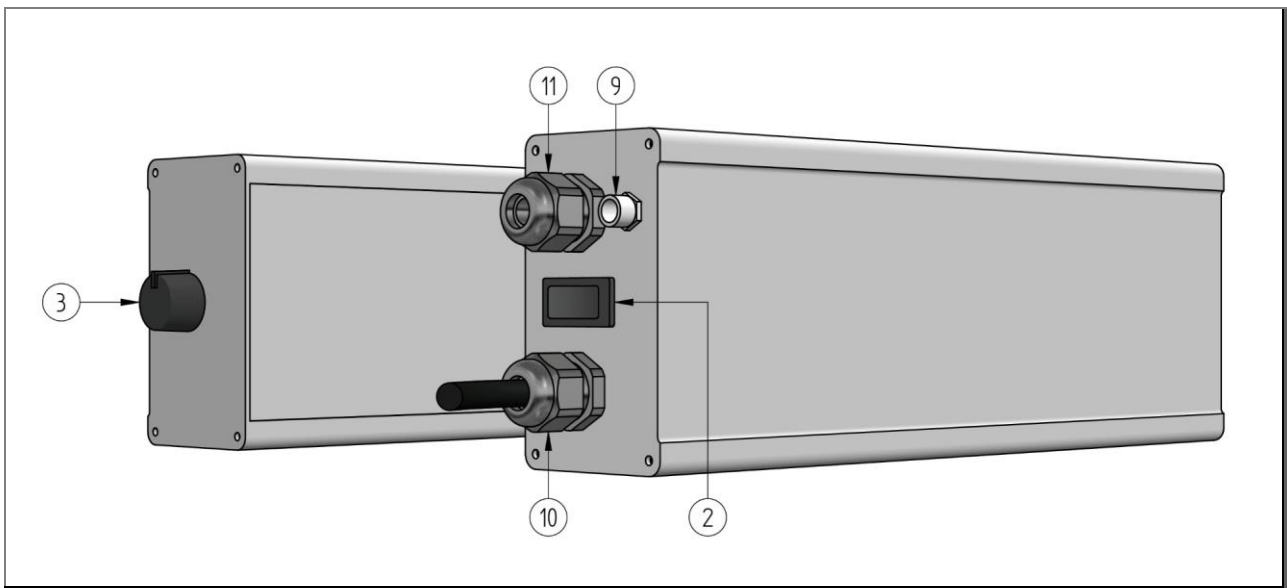

Fig. 7: Control unit (left inlet side front view, right outlet side rear view)

Item	Designation
2	Mains switch
3	Speed adjuster
9	Connection means for external stop-start signal
10	Electrical mains connection
11	Motor connection

4.3.2 Operating mode

The worm separator primarily comprises the discharge sheet and the worm roller mounted on top of it.

The separable mixed material is delivered to the top edge of the discharge sheet. Typically this can take place from a production machine, a conveyor belt or manually. The separable mixed material then slides up against the worm roller.

The worm roller has an internal drum motor with integrated electronics. This protects the motor in the event of overloading and overheating.



Caution - damage to components!

Observe the direction of rotation of the motor!

The drum motor must only be operated in one direction of rotation; with preassembled worm separators, this is already correctly set by MTF.

The direction of rotation is correct if the webs on the worm roller move in the ejection direction when the motor is switched on.

You can find further information in this respect in the chapter → Start-up.

Rotation of the worm roller and the helical webs attached to it results in a lateral conveying movement. The result of this is that larger components that do not fit between the worm roller and the discharge sheet are transported laterally and ejected from the worm separator. Smaller parts, that pass through the separating gap, slide on to the end outlet of the worm separator and it is only here that they fall down.

The adjustment of the separating gap (between the worm roller and discharge sheet) is performed by adjusting the height of the roller axle holding fixture. The worm roller can be raised and lowered using threaded rods and knurled nuts. You can find further information in this respect in the chapter → Start-up.

Also optionally available is a scraper made from polyester. This is attached above the worm roller and prevents unintentional jumping over of the material being separated. The scraper can be adjusted in respect of its gradient and separation from the worm roller.

You can find further information in this respect in the chapter → Start-up.

4.4 Connections

4.4.1 Electrical connection

All received electrical components are correctly connected and linked to each other upon first assembly by MTF Technik.

The power supply to the machine is created by connecting the mains plug to a suitable power socket.

NOTE



- Mains voltage: 230V AC ($\pm 15\%$), 50-60Hz
- The power supply must be correctly earthed!

A plug is connected to the socket for an external stop-start signal. As supplied, the plug includes a jumper. This provides a potential-free connection between pins 3 and 4 of the control unit. If the worm separator is to be stopped and started via an external signal, the plug is connected in this way with the external signal line.

NOTE



- Start release for the motor: Potential-free connection between pin 3 and 4 must be closed.
- Stop signal at the motor: Potential-free connection between pin 3 and 4 must be open.

DANGER

Danger to life due to electric current

There is danger to life in the event of contact with live components.

Active electrical components may perform uncontrolled movements. Serious injuries or even death may result.

- All work on the electrical components of this machine must only be carried out by qualified specialist personnel (electricians or persons trained in electrical engineering in accordance with DIN EN 60204-1).
- Switch the machine off during maintenance and repair work and secure to prevent unexpected switching back on.
- Close the working area off and mark it with a warning sign.

4.5 Displays and operating elements

4.5.1 Mains switch

The mains switch is located on the rear side of the control unit. The entire machine is switched to a voltage-free state via the mains switch.



Caution - damage to components!

Damage to the mains adapter

Frequent, quickly repeating ON/OFF switching of the mains voltage can result in destruction of the mains adapter. Damage resulting from such behavior is not covered by the manufacturer's warranty.

4.5.2 Speed adjuster

The control dial for speed adjustment is located on the rear side (separated material output side).

NOTE



-
- The speed of the worm roller can be adjusted in 15 steps from 15 to 92 rpm.
-

The speed can be changed as follows:

- Increasing the speed: Turn the dial **clockwise**
- Reducing the speed: Turn the dial **anticlockwise**

4.6 Modes of operation

4.6.1 Normal operation

When switched on, the machine automatically implements “Normal mode”. Different worm speeds can be selected in normal mode.

4.7 Accessories and tools

4.7.1 Accessories

Insofar as your worm separator does not have a scraper, you can procure it as an optional accessory. You can find further information in this respect in the chapter “Spare parts”.

4.7.2 Tools

The following tools are required from start-up and maintenance of a worm separator:

- Wrench set for alignment of the optional scraper.

5 Packaging and transport

5.1 Safety

Only specialized personnel with proven qualification (see the “Safety” chapter) are authorized to perform work on the system. Compliance with the following is mandatory:

- this instruction manual
- all other instruction manuals pertaining to the system (further applicable documents, including the documents provided by the suppliers)
- the applicable local regulations and laws.

There is an increased risk of injury and damage to property if unqualified personnel and unsuitable or damaged lifting devices, lifting accessories and transport equipment are used. This is why the persons responsible for the transport must be trained at regular intervals.

Compliance with the safety instructions in the “Safety” chapter is mandatory for transport.

NOTE

The transport must be performed by the operator or by personnel who are appointed by the operator. When transporting the system to its destination, all of the applicable local regulations and laws must be observed.

DANGER

Suspended loads

Tipping or falling loads may cause serious or even fatal injuries.

- Never step or stand under suspended loads.
- Only use approved lifting devices and lifting accessories that are rated for the total weight of the suspended load.
- Keep the suspension points and the center of gravity of the load in mind.
- Only use lifting accessories and load-handling equipment that are in a perfect technical state.
- Secure the loads with suitable means.
- If transport locks are used, do not remove them until the assembly is complete.
- Close the loading areas off against unauthorized access.
- Ensure sufficient lighting of the loading areas.
- Move loads only under supervision.
- Set the load down when leaving the workplace.

WARNING

Crushing of limbs between components

Loads falling down during transport may crush limbs and cause serious injuries.

- Only use suitable means of transport.
- Secure the loads adequately during transport.
- Wear personal protective equipment.

⚠ CAUTION

Risk of tripping and falling

There is a risk of tripping and falling at the supports due to projecting frame parts.

- The machine, and in particular the support, must not be set up and operated near to walkways.
- If necessary, existing walkways must be changed accordingly.

ATTENTION

Damage to property due to improper load handling

Improper handling of the load during loading or unloading may cause damage to property.

- Use suitable lifting devices.
- Loads that can be dismantled or mounted and that are too heavy to be carried manually must be kept in place using suitable devices (ropes or a block and tackle).
- Chafing of ropes and webbing slings on sharp edges and corners must be prevented by way of special devices, e.g. intermediate layers of a softer material, corner protectors or edge protectors.
- Components and their attachments must not be compressed by ropes or chains pulling at angles.
- Avoid strong impacts when setting the load down.
- Loads may be set down only on firm and level ground.

5.2 Check of the delivery

1. Remove the transport packaging of the machine or of the individual components.
2. Check the machine for signs of transport damage.
 - Notify the shipping company and the manufacturer immediately in writing of any damage.
 - Provide protection against further damage.
3. Check the delivery for completeness against the bill of delivery.

5.3 Unloading, transport into a building, setting-down

1. Only use suitable lifting devices with a load-bearing capacity that corresponds to twice the total weight of the load.
2. Check the integrity of the ropes and chains.
3. Position the crane centrally above the goods to be transported.
4. Attach ropes to the attachment points that are intended for this purpose.
5. Lift the load slowly and keep an eye on the environment.
6. If necessary, use additional control ropes in order to hold the load in position.
7. Set the conveying goods safely down on a sufficiently load bearing surface.

5.4 Unpacking

ATTENTION

Risk of environmental damage

The environment will be harmed if the disposal is not performed properly.

- Comply with the local regulations and statutory provisions for the disposal.

1. Remove the packaging material prior to the installation.
2. Dispose of the packaging material in a proper manner.

6 Installation and first start-up

6.1 Installation: General note

Installation takes place during first assembly of the system as a whole by the manufacturer in its own factory. The system is preassembled and delivered after a successful test run. All parameters to be set are optimally preset and in general do not require any adjustment.

NOTE



- The installation is already completed upon delivery.

6.2 Safety

Only specialized personnel with proven qualification are authorized to perform work on the system. Compliance with the following is mandatory:

- this instruction manual
- all other instruction manuals pertaining to the system (further applicable documents, including the documents provided by the suppliers)
- the applicable local regulations and laws.

NOTE



The manufacturer does not accept any liability for damage resulting from improper start-up.

DANGER

Danger to life due to electric current

There is danger to life in the event of contact with live components. Active electrical components may perform uncontrolled movements. Serious injuries or even death may result.

- All work on the electrical components of this machine must only be carried out by qualified specialist personnel (electricians or persons trained in electrical engineering in accordance with DIN EN 60204-1).
- Switch the machine off during maintenance and repair work and secure to prevent unexpected switching back on.
- Close the working area off and mark it with a warning sign.

DANGER

Lack of avoidability of dangers

Avoidance and reduction of personal injury will not be possible if switching off devices are rendered inaccessible.

- Do not block or otherwise render inaccessible switching off devices.

⚠ WARNING**Risk of injury due to negligent actions during troubleshooting**

Severe injuries such as crushing, abrasion or loss of limbs may result.

- The machine must ALWAYS be shut down during troubleshooting and secured to prevent switching back on!
- Do not reach into the inlet area if the separating worm is rotating!
- Ensure you keep all limbs clear of the rotating separating worm!
- Wear tight-fitting clothes when working on the separating worm!
- Do not wear gloves!

⚠ WARNING**Risk of crushing and impacts**

During adjustment work on the support, the machine may lower unexpectedly due to insufficient safeguards.

- Secure the machine with suitable load handling equipment (crane, etc.) to prevent unintentional and sudden lowering.
- The retaining screws may only be released once the machine has been correctly secured to prevent the referred to hazard.
- Never remain under suspended loads when loosening/fastening the retaining screws.
- Maintain a sufficient distance from the danger locations.
- Carry out height adjustment using several persons.
- Wear personal protective equipment.

ATTENTION**Damage to the equipment due to incorrect voltage**

If the equipment is connected to an incorrect voltage supply, the electrical equipment may be destroyed.

- The voltage supply should be connected by skilled electricians only.
- Observe the local rules and regulations concerning the energy supply. The electrical equipment complies with the European safety standards.

6.3 First start-up



Caution – health hazards and damage to components!

Carry out the following steps completely and conscientiously in the specified sequence.

- 1 Ensure that
 - In the case of a worm separator with support, it stands stably and horizontally on the ground.
 - In the case of an add-on worm separator, it is securely and safely connected to the corresponding device (in the rule a conveyor belt). The unit on which the add-on worm separator is fitted, must likewise be checked for secure standing.
- 2 Ensure that the area around the machine is free from tools or other foreign objects that had to be used for the installation or assembly.
- 3 Clean the system to remove all traces of moisture and dirt.
- 4 Ensure that the mains switch is in the “Off” position.
- 5 Turn the speed adjuster anticlockwise to minimum speed.

NOTE



-
- Ensure that the plug is correctly screwed in to the socket for the external stop-start signal.
 - For the plug pin assignments, please refer to the chapter “Electrical connection”.
-

- 6 Make sure that mains power is available and reliable.
To do so, connect the machine mains plug to the mains via a suitable power socket.
- 7 Switch the machine on at the mains switch.
- 8 Set the desired worm speed via the speed adjuster. The change in speed can take place with the worm roller rotating.
- 9 The system is now operational.

6.4 Setting the separating parameters



Warning - general hazards!

The steps described in this chapter may only be performed if the machine is switched off and the mains plug has been pulled out!

6.4.1 Setting the separating gap

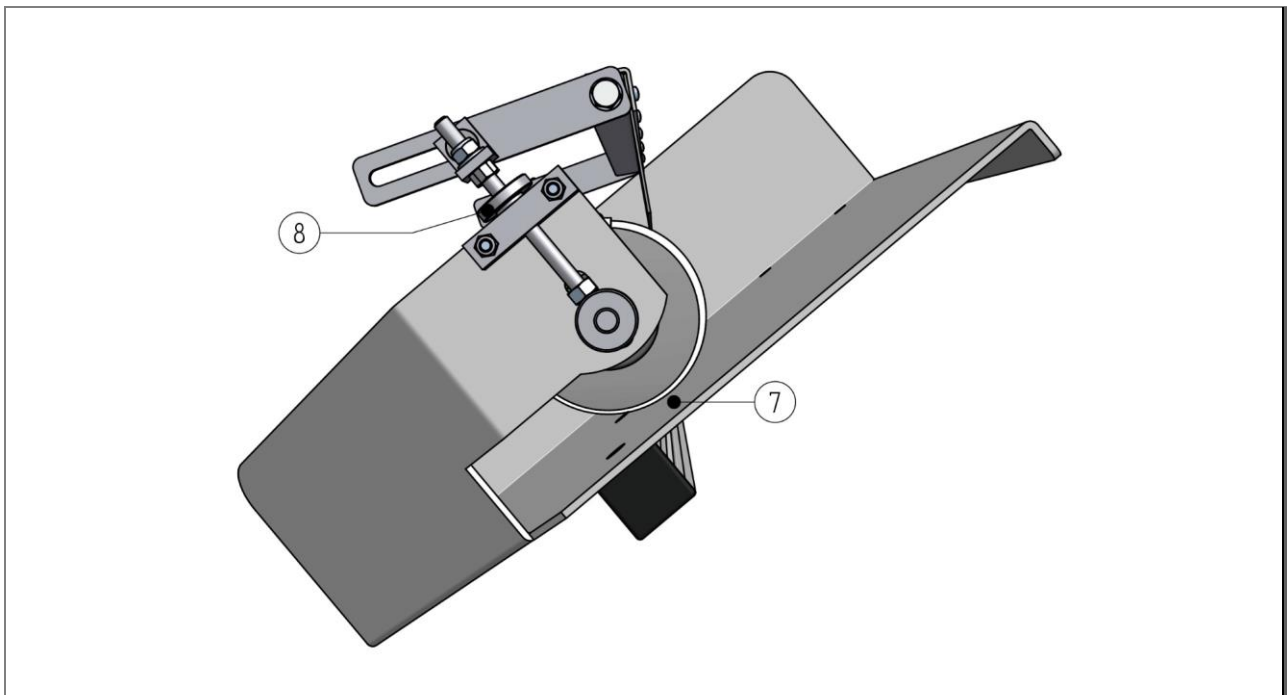

Fig. 8: Side view with separating gap

To set or adjust the separating gap **(7)** for the product to be separated, the worm roller can be raised or lowered by turning the knurled nut **(8)**. Clockwise rotation raises the worm roller. Anticlockwise rotation lowers the worm roller.

Set the height of the separating gap using a product template so that the greater part of the material to be separated does not slide through below the worm roller. In doing so, the distance between the roller base body and the discharge sheet must be considered, not the measurement between the worm webs and the discharge sheet. In this way an optimum separating result is achieved because all small parts can pass through with a maximum distance to the worm roller.

Ensure that the separating gap is set on both the left and right of the roller to the same distance relative to the discharge sheet.

6.4.2 Setting the gradient, height and alignment

Dependent on the machine type, please read the corresponding subchapter for adjustment of the worm separator.

6.4.2.1 MSL/MSR support



Fig. 9: MSL/MSR support



Warning - general hazards!

Before any adjustment to the support, secure it to prevent its falling down. Securing can be achieved by use of a suitable lifting accessory or a second person.

To set the gradient, loosen the upper clamping screw **(12)**. The worm separator can now be adjusted to the desired gradient via its pivot point. The optimum gradient depends on the material being separated.

The inlet and outlet height can be adjusted after loosening the clamping screws **(13)**.

Retighten all the screws after adjustment is completed.

6.4.2.2 SAL/SAR supporting frame

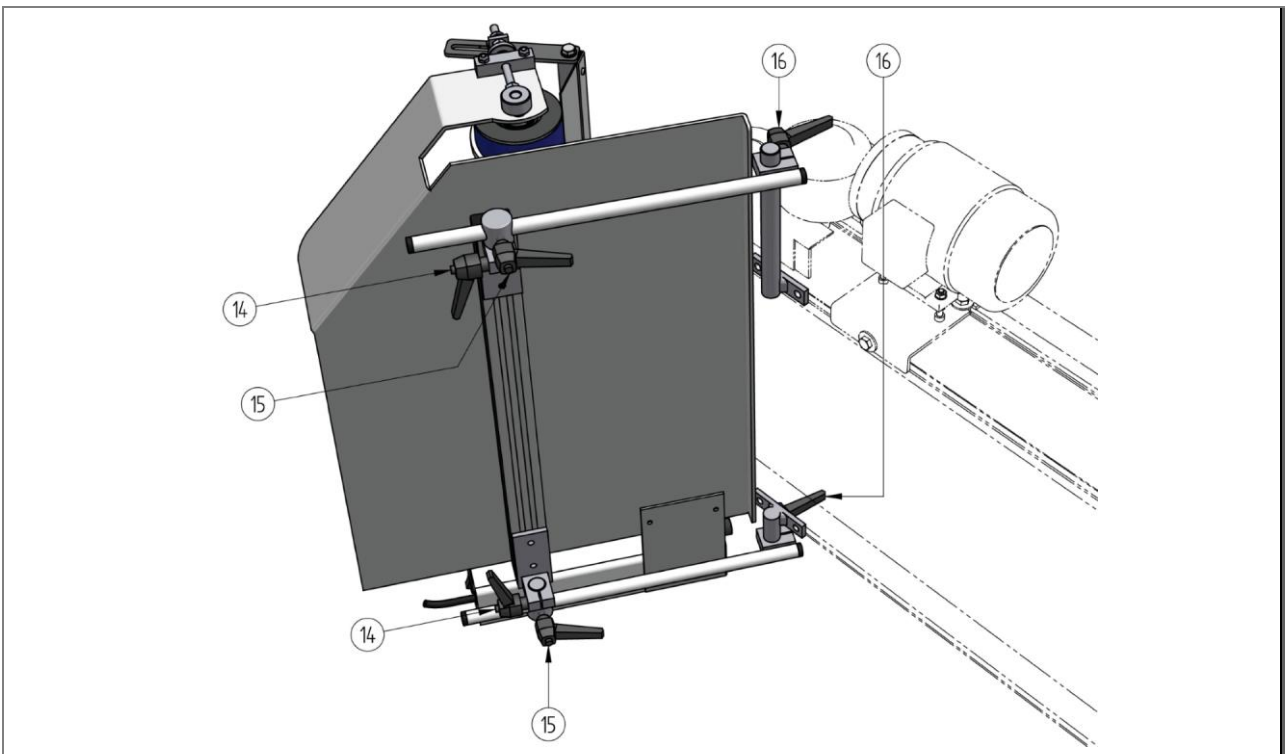

Fig. 10: SAL/SAR supporting frame



Warning - general hazards!

Before any adjustment to the supporting frame, secure it to prevent it from falling down. Securing can be achieved by use of a suitable lifting accessory or a second person.



Warning - general hazards!

Prior to every adjustment, the superordinate machine, for example a conveyor, must likewise be shutdown and secured to prevent it being switched back on.

To set the gradient, loosen the clamping screws **(16)**. The worm separator can now be adjusted to the desired gradient via its pivot point. The optimum gradient depends on the material being separated.

The gradient of the worm separator can likewise be set via the clamping screw **(14)**. The optimum alignment depends on the material being separated and the transfer to the worm separator.

The clamping screw **(15)** is used to set the distance to the superordinate machine (for example the conveyor).

NOTE



- Always maintain a distance of at least 30mm between the discharge sheet and moving parts such as a conveyor belt.

Retighten all the screws after adjustment is completed.

6.5 Start-up after a planned shutdown

The following steps must be performed for each start-up:

- 1 Clean the system to remove all traces of moisture and dirt.
- 2 Make sure that mains power is available and reliable.
To do so, connect the machine mains plug to the mains via a suitable power socket.
- 3 Switch the machine on at the mains switch.
- 4 Set the desired worm speed via the speed adjuster. The change in speed can take place with the worm roller rotating.
- 5 The system is now operational.

NOTE



- If the machine is restarted after a longer shutdown of more than one week, repeat the first start-up procedure (see preceding chapter).
-

7 Operation

The chapter “Operation” describes the operation of the system under normal operating conditions and provides an overview of the controls and warning devices. After the activation of the system under normal conditions, it runs fully automatically without needing any interventions by the system operator.

7.1 Safety

Only specialized personnel with proven qualification are authorized to perform work on the system. Compliance with the following is mandatory:

- this instruction manual
- all other instruction manuals pertaining to the system (further applicable documents, including the documents provided by the suppliers)
- the applicable local regulations and laws.

DANGER

Danger to life due to electric current

There is danger to life in the event of contact with live components. Active electrical components may perform uncontrolled movements. Serious injuries or even death may result.

- Work on the system should be performed by authorized and specialized personnel only.
- Prior to performing any work, switch the power supply off at the mains switch on the control cabinet and lock it so that it cannot be switched on again.
- Close the working area off and mark it with a warning sign.

WARNING

Hazards caused by rotating or moving components

Rotating and moving components may crush or sever limbs and cause serious injuries.

- Stay within the defined working area.
- Keep a safe distance to the components.
- Heed any warning signs in the working area.
- Wear personal protective equipment.
- Wear tight-fitting clothes.
- Knot long hair together and wear a hair net as necessary.

WARNING

Serious injuries caused by moving parts

There is a risk of serious injuries if objects or body parts get caught in or are pulled into any moving parts of the machine.

- Stay within the defined working area.
- Keep a safe distance.
- Wear tight-fitting clothes.
- Wear head protection.

NOTE

The accident prevention regulations as well as any internal operating procedures and safety instructions must be observed in addition to the other regulations and instructions.

7.2 Prior to operation

Improper use of the system or misconduct may cause life-threatening injuries and damage to property. This is why the information in the “Safety” chapter must be strictly followed when using and operating the system. The persons responsible for the operation of the system must be trained at regular intervals.

Prior to using or operating the system, the following points must be checked and considered:

- Have I read and understood the operating instructions?
- Am I authorized to operate the system based on my training and qualification?
- Have I been authorized to operate the system by the operator?

Moreover, undertake the following preparatory actions for operation and use of the machine:

- Have available and wear personal protective equipment.
- Familiarize yourself with the entire system.
- Familiarize yourself with the applicable rules and regulations.
- Coordinate the operating procedures with all of the persons involved.
- Check the state of the machine for signs of damage prior to starting any work.

7.3 Operating and display elements

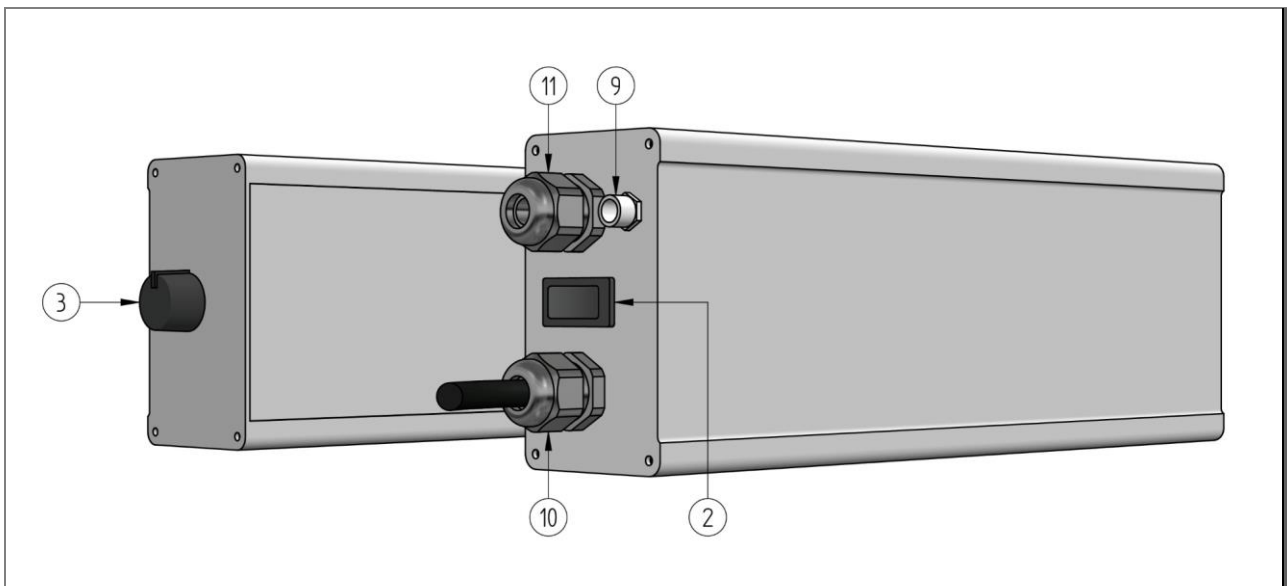

Fig. 11: Control unit

The machine has the following operating elements:

- Pos. 2: Mains switch
- Pos. 3: Speed adjuster

7.4 Switching the machine on

Perform the following steps to switch the machine on:

1. Set the mains switch on the control unit of the machine to "ON".

7.5 Operating modes

The standard operating mode of the system is the automatic mode. After switching on the system, the conveying process starts up. No further intervention is required. The following operating modes describe the general state of the machine during specific tasks:

No.	Operating mode	Purpose/function
1	Automatic mode	The automatic mode is the standard operating mode of the machine after it has been switched on. In this operating mode, the machine operates fully automatically.
2	Maintenance mode	In maintenance mode, the machine is deactivated via the mains switch. For maintenance tasks involving the electrical system of the machine, the machine must be physically disconnected from the power supply.
3	Test mode	This mode can be used for a test run, for example after the completion of maintenance or overhaul tasks. The machine runs without any piece goods on the belt. Always perform a test run if components have been replaced.
4	Cleaning mode	This operating mode is used for cleaning. In cleaning mode, the machine is deactivated via the mains switch. For cleaning tasks involving the electrical components of the machine (motors, control cabinet, etc.), the machine must be physically disconnected from the power supply.

7.6 Switching the system off

Perform the following steps to switch the system off:

1. Wait until the system has completely transported away all the piece goods it contains.
2. Set the mains switch on the control unit of the machine to "OFF".

8 Maintenance

8.1 Safety

Only specialized personnel with proven qualification are authorized to perform work on the system. Compliance with the following is mandatory:

- this instruction manual
- all other instruction manuals pertaining to the system (further applicable documents, including the documents provided by the suppliers)
- the applicable local regulations and laws.

⚠ DANGER**Danger to life due to electric current**

There is danger to life in the event of contact with live components. Active electrical components may perform uncontrolled movements. Serious injuries or even death may result.

- Work on the system should be performed by authorized and specialized personnel only.
- Prior to performing any work, switch the power supply off at the mains switch on the control cabinet and lock it so that it cannot be switched on again.
- Close the working area off and mark it with a warning sign.

⚠ WARNING**Fall hazard when working at height**

Work at height may cause slipping, falling, and serious injuries.

- Wear personal protective equipment.
- Ensure safe working conditions in time.
- Always use fall protection equipment when secure footing cannot be guaranteed.
 - Use, for example, work platforms, scaffolds, personnel elevators, or cherry pickers.
- Protect the installation area against falling objects.
- Never work alone.

⚠ CAUTION**Sharp edges**

Sharp edges may cause cutting.

- Wear personal protective equipment.
- Be careful when handling objects with sharp edges.

ATTENTION**Damage to the equipment due to incorrect voltage**

If the equipment is connected to an incorrect voltage supply, the electrical equipment may be destroyed.

- The voltage supply should be connected by skilled electricians only.
- Observe the local rules and regulations concerning the energy supply. The electrical equipment complies with the European safety standards.

ATTENTION**Equipment damage to the machine due to unsuitable cleaning agents**

The machine may be damaged if solvents are used for cleaning.

- Do not use solvents for cleaning.
- Remove normal dirt with lukewarm water.
- Remove greasy stains with white spirit.
- Contact the manufacturer if you have any questions concerning suitable cleaning agents.

NOTE



The manufacturer does not accept any liability for damage resulting from faulty maintenance, repair or overhaul.

8.2 Maintenance instructions

The purpose of maintenance is to maintain the functionality of the machine or to restore it after a malfunction or failure.

The machine must be maintained regularly. Inadequate maintenance may cause malfunctions or damage which in turn will lead to downtimes and repair costs.

This chapter includes information that is intended for trained, qualified, and specialized personnel.

Contact the manufacturer immediately in the event of problems or if anything is unclear.

When submitting a query, please provide the following:

- You can find the information on the type plate of the machine
 - Serial no.
 - Type designation
 - Year of manufacture
- A precise description of the fault/malfunction.
- Troubleshooting measures taken so far.

If the machine is sent in to the manufacturer, refer to the chapters, “Disassembly” and “Transport”.

8.3 Preparation for maintenance

Prior to performing any maintenance, repair or overhaul tasks on the system, observe the following points:

1. Inform the operating personnel prior to commencing the tasks.
A supervisor must be appointed.
2. Comply with the maintenance intervals that are stated in the maintenance plan.
3. The working area must be closed off against unauthorized access and marked with a warning sign.
4. Do not perform any work on the system unless it is at a complete stop.
 - Disconnect the system from the power supply
5. In order to perform the necessary tasks, switch the system or the affected part of the system off and then lock it so that it cannot be switched on again.
 - Pull out the mains plug
 - Attach a warning sign
 - Cordon off a wide area
6. To avoid electric shock, do not open any electric components, housings or covers. Do not touch any damaged or live parts.
7. Work on the electrical system must be performed exclusively by an authorized and qualified person who has undergone special training in this field.
8. If it is necessary to remove any of the safety devices or guards, they must be reinstalled and checked for correct operation immediately after the completion of the work.
9. If parts of the system or large assemblies need to be replaced, fasten and secure them thoroughly on the lifting devices. Use only suitable lifting devices and load-handling attachments and ensure that they are in a perfect technical state and have a sufficient load-bearing capacity.
10. Use adequate climbing aids and working platforms, which are in line with the safety requirements, when performing overhead installation work. Do not climb or step on any parts of the system.

8.4 Maintenance plan

Intervals	Component	Measures	What to do in the event of a defect
Daily	Overall machine	General visual inspection	Shutdown the machine. Rectify the defect.
Weekly	Worm roller	Visual inspection for soiling	Clean the worm roller
Monthly	Mechanical components	Check all screws and nuts for tightness and retighten if necessary	Replace the component
	Drum motor	Check for outer visible damage	Replace the drum motor
	Electrical installation	General inspection, in particular for damaged cables, connectors	Replace the component
Every six months	Worm roller	Checking of the general state, especially surface wear	Replace the worm roller

Table 1 - Maintenance plan

Dependent on the operating conditions, the intervals may be shorter or longer.

8.5 Switching back on after maintenance

Do not use the machine if there are defects that compromise the safe operation of the machine. After the completion of maintenance and prior to starting the machine, the following points must be observed:

1. Check whether all of the screw connections are tight.
2. Ensure that all of the safety devices, guards and covers that had to be removed are properly reinstalled.
3. Ensure that all of the tools, material and other equipment have been removed from the working area.
4. Clean the working area and remove any fluids or similar substances that may have leaked out.
5. Check whether all of the safety devices and guards of the machine operate correctly.
6. Check the safety devices and guards.

9 Troubleshooting

9.1 Safety

Only specialized personnel with proven qualification are authorized to perform work on the system. Compliance with the following is mandatory:

- this instruction manual
- all other instruction manuals pertaining to the system (further applicable documents, including the documents provided by the suppliers)
- the applicable local regulations and laws.

DANGER

Danger to life due to electric current

There is danger to life in the event of contact with live components. Active electrical components may perform uncontrolled movements. Serious injuries or even death may result.

- Work on the system should be performed by authorized and specialized personnel only.
- Prior to performing any work, switch the power supply off at the mains switch on the control cabinet and lock it so that it cannot be switched on again.
- Close the working area off and mark it with a warning sign.

WARNING

Fall hazard when working at height

Work at height may cause slipping, falling, and serious injuries.

- Wear personal protective equipment.
- Ensure safe working conditions in time.
- Always use fall protection equipment when secure footing cannot be guaranteed.
 - Use, for example, work platforms, scaffolds, personnel elevators, or cherry pickers.
- Protect the installation area against falling objects.
- Never work alone.

CAUTION

Sharp edges

Sharp edges may cause cutting.

- Wear personal protective equipment.
- Be careful when handling objects with sharp edges.

ATTENTION

Damage to the equipment due to incorrect voltage

If the equipment is connected to an incorrect voltage supply, the electrical equipment may be destroyed.

- The voltage supply should be connected by skilled electricians only.
- Observe the local rules and regulations concerning the energy supply. The electrical equipment complies with the European safety standards.

9.2 Procedures in the event of malfunctions

The following fundamental rules apply at all times:

1. In the case of malfunctions or faults presenting a direct danger to persons or property, switch the system off immediately.
The operator is responsible for the integration of the system into the safety system of the overall system.
2. Determine the cause of the malfunction or fault.
3. If work must be performed in the hazard area in order to eliminate the malfunction or fault, switch the system off and lock it so that it cannot be switched on again.
4. The person at charge on site must be informed about the malfunction or fault immediately.
5. Depending on the type of malfunction or fault, it must be eliminated by authorized personnel with a qualification in the respective field.
6. If components need to be replaced, ensure that they are installed correctly.
 - Adhere to standard-compliant tightening torques.
 - Observe the required lock washers.

9.3 Preparations for troubleshooting

1. Switch the mains switch off prior to performing any work on the system.
2. Do not perform any work on the system unless it is at a complete stop.
 - Disconnect the system from the power supply
3. Lock the system so that it cannot be switched on again.
 - Padlock the mains switch
 - Attach a warning sign
 - Cordon off a wide area
4. Empty the conveying line and/or remove transported material.

9.4 Restart after a malfunction

Do not use the system if there are defects that compromise the safe operation of the system.

1. Ensure that all of the protective covers and guards are in place.
2. Check the safety devices and guards.

NOTE



Follow the instructions and information provided in the supplier documentation.

9.5 Troubleshooting



Note

- Do not perform any work on the machine unless it is at a complete stop. To do so, disconnect the machine from the power supply.
- Prior to commencing any tasks, ensure that the machine cannot be switched on by mistake or by unauthorized persons.
- Please contact our after-sales service if you encounter malfunctions or faults that are not described in this manual.

Malfunctions can be rectified according to the following troubleshooting table:

Malfunction/fault	Possible cause	Remedy
The system does not start	• No power supply	Check the position of the mains switch Check the external fuse Check whether the power supply cable is damaged or improperly connected Check the mains supply
	• Release for the drive is missing	Check whether there is electrical contact between pin 3 and 4 of the control unit
	• Motor connection cable damaged	Replace the motor
	• Motor defective	Replace the motor
Check whether any of the electrical components are damaged. Machine malfunctions	• Damaged cable or switch • Exposed live components • Damaged electrical components	Shut the system down immediately and repair it
Unsatisfactory separation result	• Separating gap set incorrectly	Set the separating gap correctly for the material currently being separated
	• Incorrect speed	Reduce or increase speed
	• Incorrect gradient of the discharge sheet	Set a flatter or steeper gradient
Components jumping over	• Unsuitable geometry of the material being separated	Set a flatter discharge sheet gradient Retrofit a polyester scraper if one is not already fitted

10 Disassembly

10.1 Safety

Only specialized personnel with proven qualification are authorized to perform work on the system. Compliance with the following is mandatory:

- this instruction manual
- all other instruction manuals pertaining to the system (further applicable documents, including the documents provided by the suppliers)
- the applicable local regulations and laws.

There is a risk of injury and damage to property if the operator fails to disassemble the system in due form and in line with the applicable regulations.

NOTE



The disassembly must be performed by the operator or by persons who are appointed by the operator.

Compliance with the applicable local regulations and laws is mandatory for the disassembly of the machine.

DANGER

Danger to life due to electric current

There is danger to life in the event of contact with live components. Active electrical components may perform uncontrolled movements. Serious injuries or even death may result.

- Work on the system should be performed by authorized and specialized personnel only.
- Prior to performing any work, switch the power supply off at the mains switch on the control cabinet and lock it so that it cannot be switched on again.
- Close the working area off and mark it with a warning sign.

WARNING

Fall hazard when working at height

Work at height may cause slipping, falling, and serious injuries.

- Wear personal protective equipment.
- Ensure safe working conditions in time.
- Always use fall protection equipment when secure footing cannot be guaranteed.
 - Use, for example, work platforms, scaffolds, personnel elevators, or cherry pickers.
- Protect the installation area against falling objects.
- Never work alone.

CAUTION

Sharp edges

Sharp edges may cause cutting.

- Wear personal protective equipment.
- Be careful when handling objects with sharp edges.

ATTENTION

Damage to property due to improper load handling

Improper handling of the load during loading or unloading may cause damage to property.

- Use suitable lifting devices.
 - Loads that can be dismounted or mounted and that are too heavy to be carried manually must be kept in place using suitable devices (ropes or a block and tackle).
 - Chafing of ropes and webbing slings on sharp edges and corners must be prevented by way of special devices, e.g. intermediate layers of a softer material, corner protectors or edge protectors.
 - Components and their attachments must not be compressed by ropes or chains pulling at angles.
 - Avoid strong impacts when setting the load down.
 - Loads may be set down only on firm and level ground.
-

10.2 Prerequisites for the disassembly

1. Shut the machine down prior to the disassembly and comply with the relevant shutdown procedures.
2. Switch the main switch off and lock it so that it cannot be switched on again.
3. Disconnect the machine from the energy supply and secure this state.
4. Disconnect the entire machine physically from the power supply.
5. Remove any coarse soiling from the machine parts.
6. Disconnect any connections, e.g. pipes.
7. Collect any process fluids and other hazardous substances.
8. Seal any open connections, e.g. pipes.

10.3 Disassembly of the electrical system

1. Switch the machine off via the main switch.
2. Ensure that the operator's grid power supply is deactivated.
3. Check whether the machine is completely voltage-free.
4. Disconnect the machine from the line power supply.

10.4 Disassembly of the mechanical system

Based on the assembly drawing and set-up plan:

1. Install the transport locks.
2. Release the floor anchors of the machine.
3. Disassemble and remove the modules of the machine based on their respective dimensions and other data.
4. Aim for a low center of gravity
5. See chapters "Packaging and transport" and "Set-up and installation" if the machine needs to be transported to another location.

11 Disposal

11.1 General notes

Only specialized personnel with proven qualification are authorized to perform work on the system. Compliance with the following is mandatory:

- this instruction manual
- all other instruction manuals pertaining to the system (further applicable documents, including the documents provided by the suppliers)
- the applicable local regulations and laws.

Knowingly or unknowingly using used/worn components, e.g. rolling bearings, toothed belts, etc., may present a hazard to persons, the environment and the system.

The following points must be observed:

- The operator is responsible for proper disposal.
- Only specialized and qualified personnel are authorized to perform the disposal.
- Drain any process fluids (oils, greases, chemical substances) and other consumables off into suitable collecting vessels and ensure their proper disposal.
- At the end of its life cycle, separate the machine into different recyclable materials and hand them over to a professional recycling company.

ATTENTION

Risk of environmental damage

The environment will be harmed if the disposal is not performed properly.

- Comply with the local regulations and statutory provisions for the disposal.

12 Spare parts

NOTE



The manufacturer does not accept any liability for damage resulting from the use of third-party parts.

- If parts need to be replaced, use only original parts. The use of third-party parts may cause damage.
- Please contact the service department if you want to order spare parts. Orders can be submitted by e-mail, fax, or phone.
- Please have the data of the type plate (e.g. serial number), order confirmation and/or spare parts list ready.
- MTF Technik recommends keeping the spare parts and wear parts, which are stated on the spare parts list, in stock on site in order to reduce or avoid waiting times and downtimes in the event of faults or malfunctions.
- In all other cases, spare parts should be ordered in good time in order to ensure that they are available for the next scheduled maintenance. Spare parts have varying delivery times. This is why an extensive spare parts order based on the longest delivery time is recommended.

12.1 Viewing the spare parts list

The spare parts list of the described conveyor can be accessed online:



<https://mtf-technik.de/de/service/download/download-sprachen/download-daten/d-a-ch>

Fig. 12: Spare parts list: GL conveyor

12.2 Exploded drawing

The following figures provide an exploded view of the machine. Item numbers shown are described in the following table.

NOTE



The following technical information is required for spare parts orders:

- ID number or drawing number of the spare part
- Nominal width of the worm separator (see order)
- Discharge direction, seen in the material flow direction
- Variant with or without spikes (for loosening of the material being separated)
(If with spikes: number of spikes)
- For a stainless-steel worm roller, specification of the height of the worm web

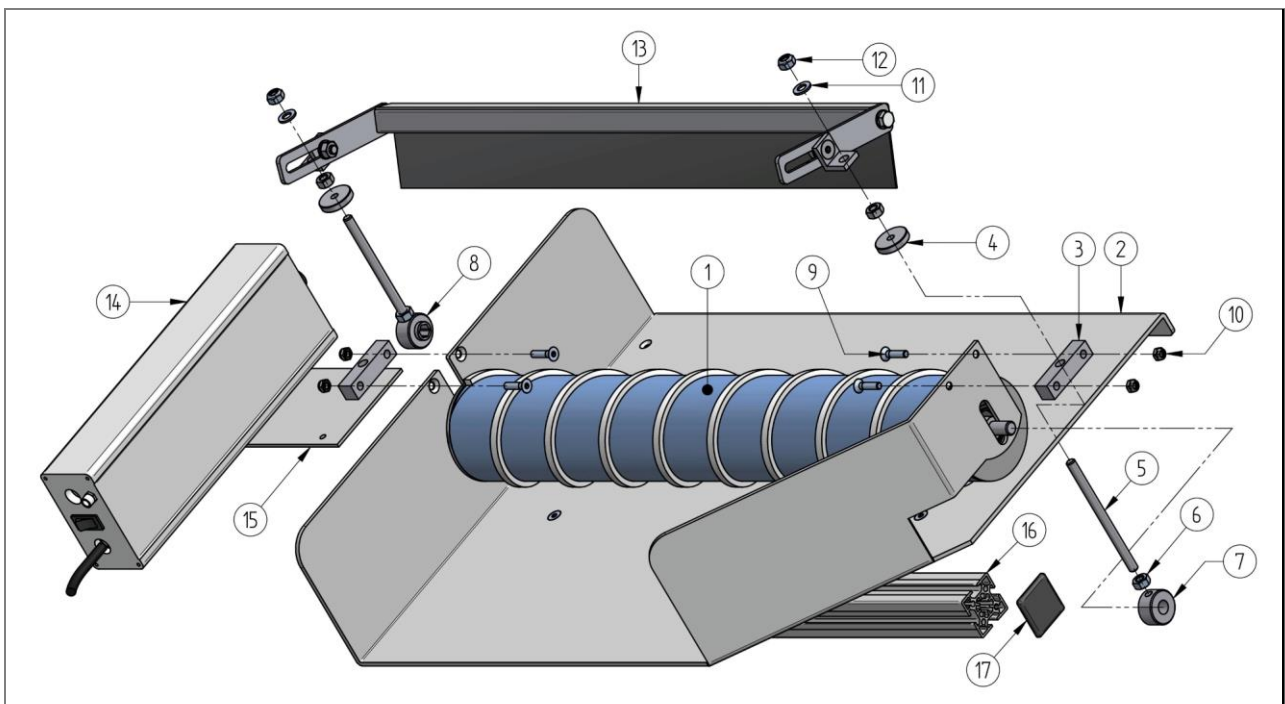

Fig. 13: Exploded drawing of a worm separator

12.3 Spare parts list, worm separator

Pos.	Qty	Name		ID no.	Drawing no.
1	1	Drum motor with worm			(page 69)
2	1	Base frame	600, left, aluminum	1008541	M.500.0004
			800, left, aluminum	1008542	
			600, left, stainless steel	1009739	
			800, left, stainless steel	1009741	
			600, right, aluminum	1008543	M.500.0010
			800, right, aluminum	1008544	
			600, right, stainless steel	1010532	
			800, right, stainless steel	1014537	
3	2	Pressure piece		1005303	E.800.0772
4	2	Knurled nut		1007003	
5	2	Threaded rod		1005511	
6	4	Hexagon nut		975108	
7	1	Adjusting ring		1007932	E.500.0057
8	1	Adjusting ring	Cable outlet side	1009786	E.500.0129
9	4	Countersunk screw		975344	
10	4	Hexagon nut		975113	
11	2	Washer		975201	
12	2	Hexagon nut		975114	
13	1	Worm scraper	600		U.500.0008
			800		U.500.0009
14	1	Control unit	Left ejecting	1012326	T.905.0021
			Right ejecting	1013583	
15	1	Holder attachment	Aluminum	1014538	E.500.0125
			Stainless steel	1014539	
16	1	Profile 40x40 MTF	Length = NB - 65	1005676	
17	2	Cover cap		1004569	

Tab. 2: Spare parts, worm separator

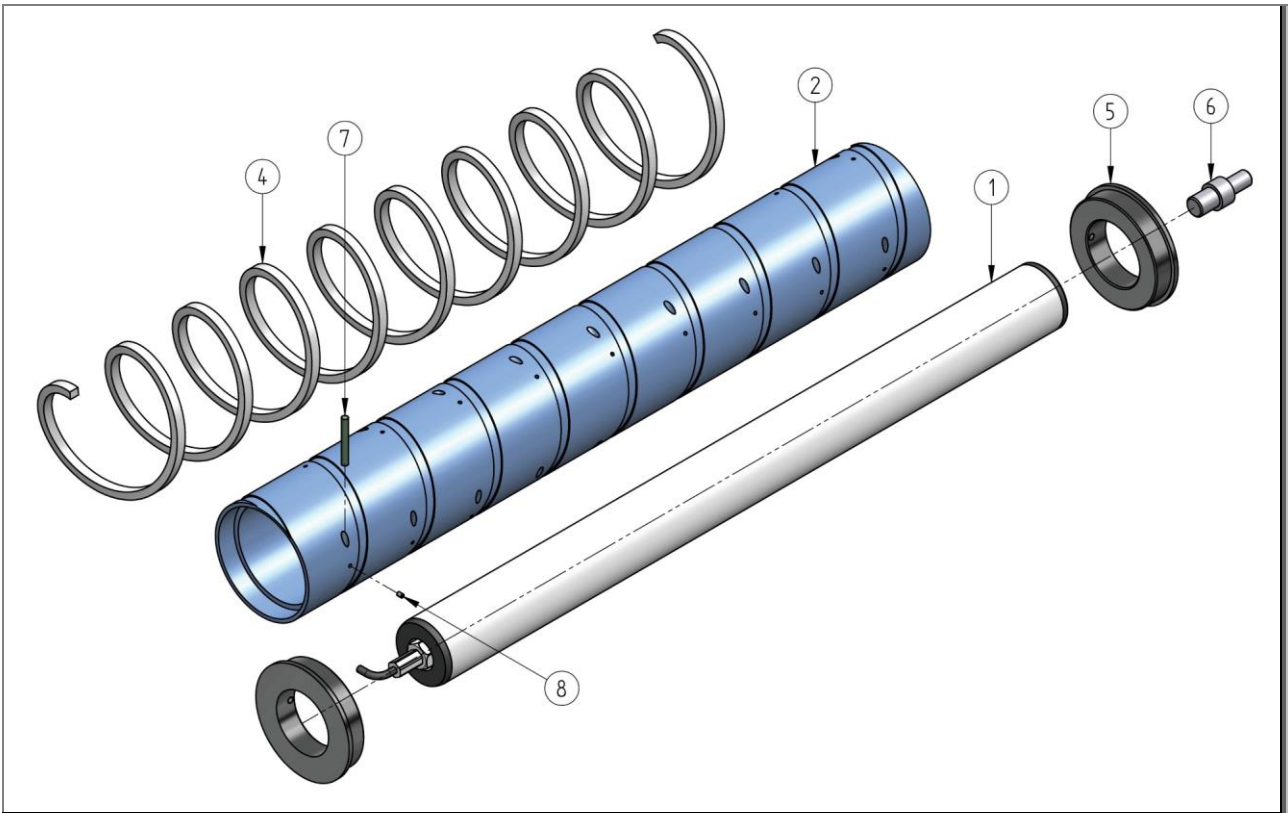

Fig. 14: PVC worm roller (standard) with motor

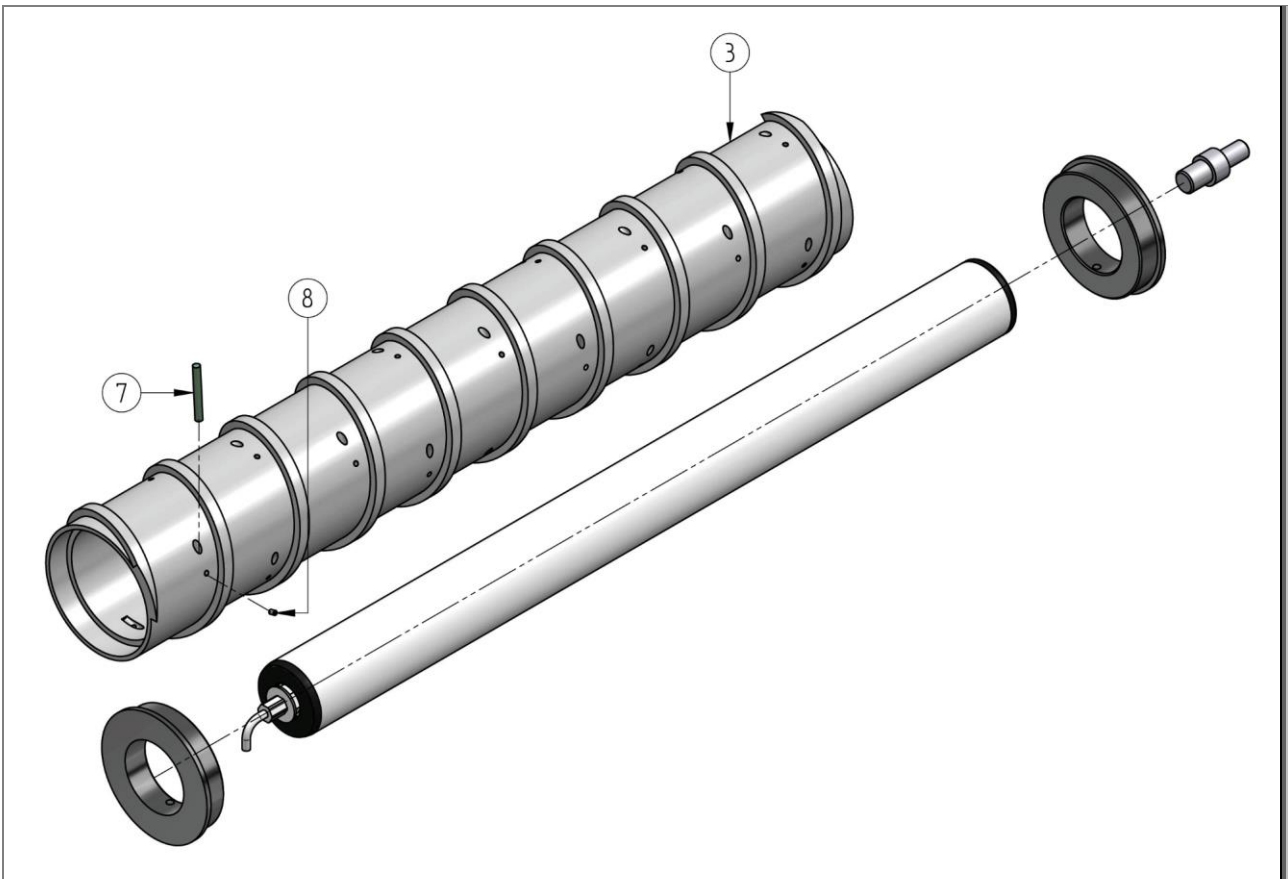

Fig. 15: Stainless-steel worm roller with motor

12.4 Spare parts list, worm roller

Pos.	Qty	Name		ID no.	Drawing no.
1	1	Drum motor	600	1019102	
			800	1019103	
2	1	Worm roller	600, left, PVC	1007947	M.911.0013
			800, left, PVC	1007948	
			600, right, PVC	1009101	M.911.0014
			800, right, PVC	1009102	
3	1	Worm roller	600, left, stainless steel		M.911.0016
			800, left, stainless steel		
			600, right, stainless steel		M.911.0017
			800, right, stainless steel		
4	1 (600) 2 (800)	PE strip	7.8x3	1001768	M.800.0010
			7.8x4	1001769	
			7.8x5	1001770	
			7.8x6	1001106	
			7.8x8	1001772	
5	2	Clamping ring		1010305	E.500.0142
6	1	Axle		1012388	E.500.0219
7	-	Polycord spike		1003533	
8	-	Grub screw		1011183	

Tab. 3: Worm roller spare parts

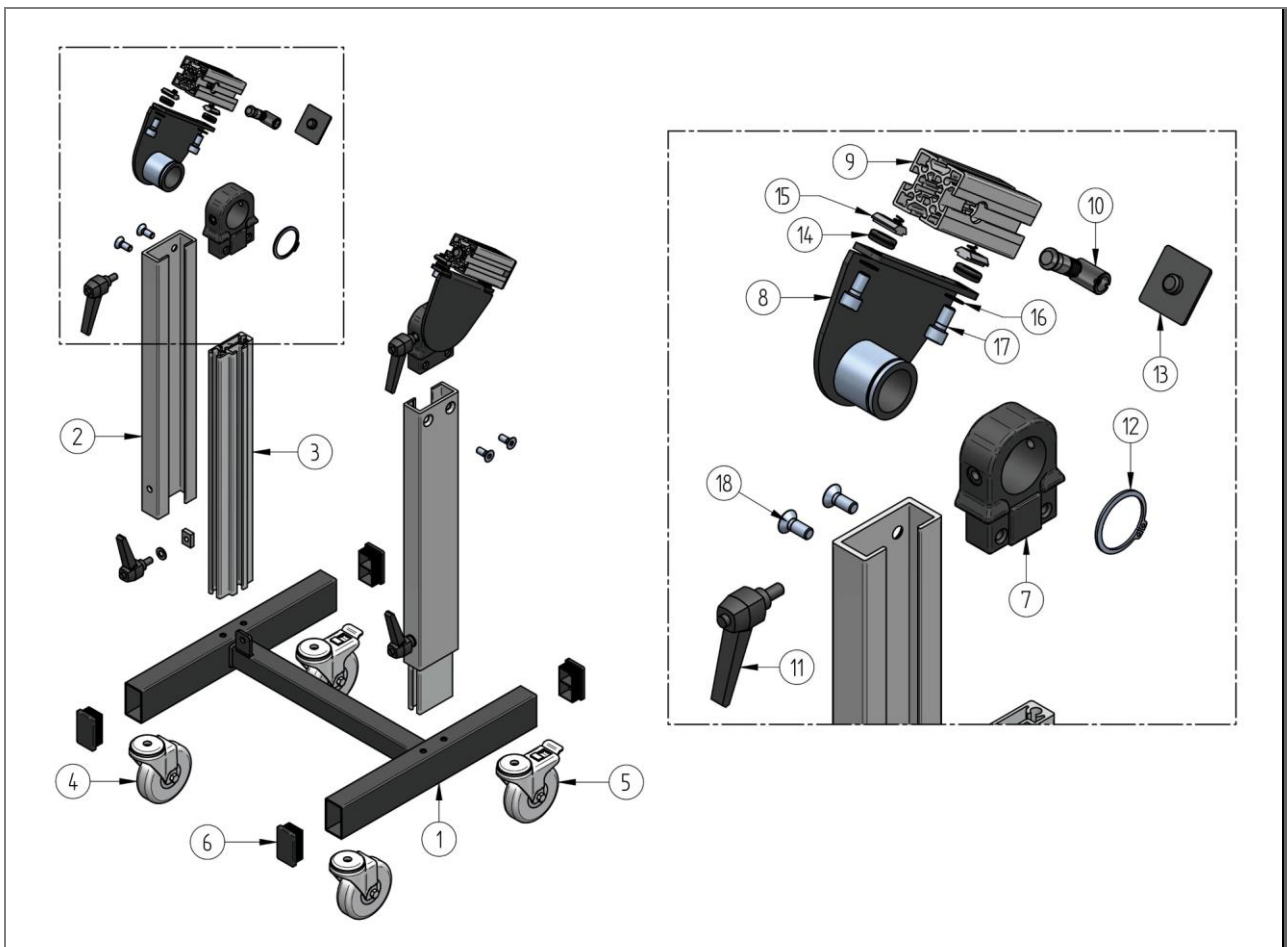

Fig. 16: MSL/MSR support

12.5 Spare parts list, MSL/MSR support

Pos.	Qty	Name		ID no.	Drawing no.
1	1	Base frame	600 (400fsm)	1000291	U.800.0007
			800 (600fsm)	1000293	
2	2	Profile IC73	Length 375 (standard)	1000196	E.918.0036
3	2	Profile CG73	Length 400 (standard)	1000197	E.918.0037
4	2	Swivel caster without lock		1004573	
5	2	Swivel caster with total lock		1004574	
6	4	Cover cap	Plastic, black	1000679	
7	2	Clamp CG73		1000017	E.800.0174
8	2	Angle adjustment device	Module 0005	1000551	T.800.0030
9	2	Profile 40 MTF	Length 90	1005676	
10	2	Connection kit		1004380	
11	4	Clamping lever		835113	
12	2	Circlip		975211	
13	2	Cover cap		1004569	
14	4	Rubber pad		1007313	
15	4	Slot nut with spring		1004570	
16	4	Washer S8		1000587	
17	4	Hexagon socket head cap screw with low head		975058	
18	4	Countersunk screw		975312	

Tab. 4: Spare parts, MSL/MSR support

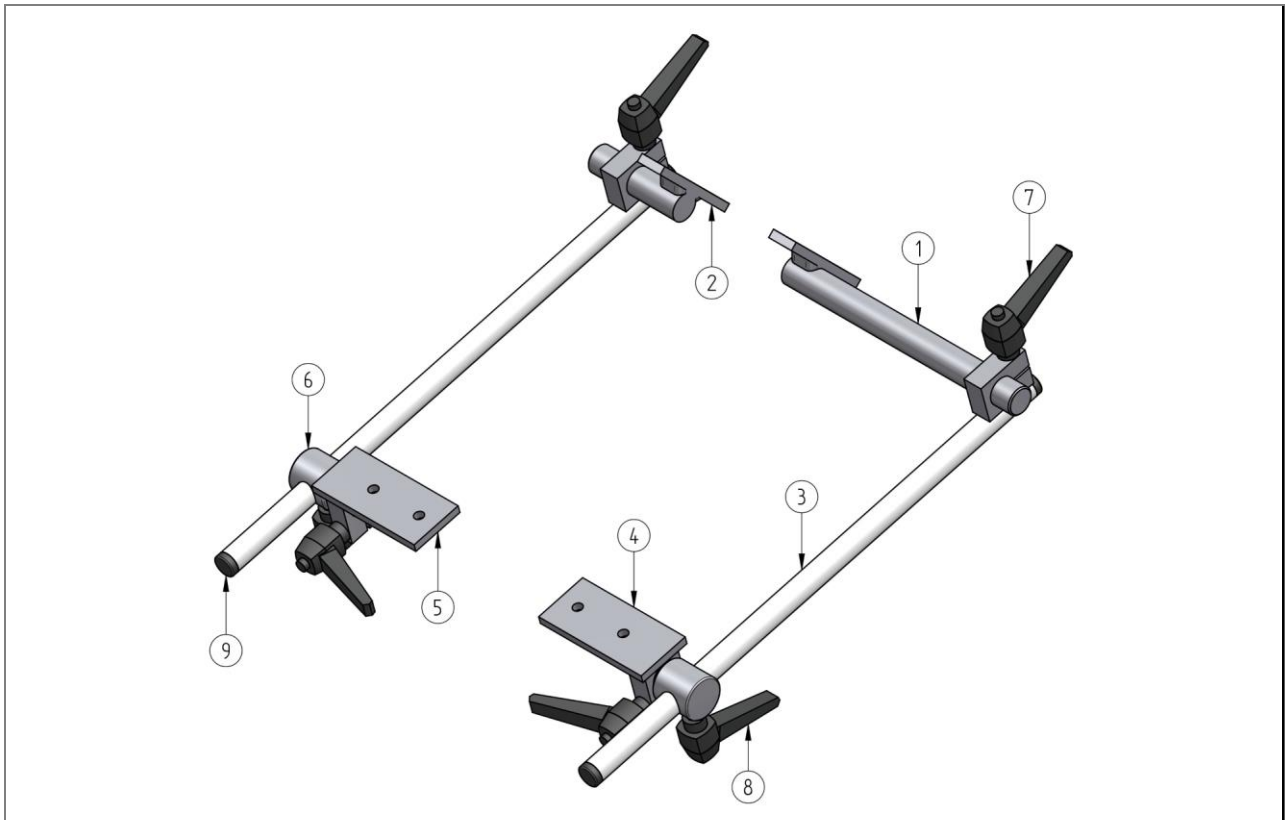

Fig. 17: SAL/SAR mounting frame

12.6 Spare parts list SAL/SAR mounting frame

Pos.	Qty	Name		ID no.	Drawing no.
1	1	Bracket for SAB		1008539	U.800.0055
2	1	Bracket for SAB		1002214	U.800.0055
3	2	Hollow tube frame		1008417	T.500.0020
4	1	Connecting bracket	Left	1008418	T.500.0019
5	1	Connecting bracket	Right	1008419	T.500.0019
6	2	Pivot point bracket		1007936	E.500.0059
7	4	Clamping lever		1007996	
8	2	Clamping lever		835113	
9	4	Cover cap		975420	

Tab. 5: Spare parts SAL/SAR mounting frame

13 Keywords index

A

Abbreviations 7
Accessories 38

B

Brief description 30

C

Compressed air 23
Connections 36

D

Disassembly 63
Displays and operating elements 37
Disposal 41, 64

F

Functional description 32

I

Installation 42

M

Malfunctions and faults 59
Misuse 12
Modes of operation 38

O

Operating and display elements 51

Operating instructions 15
Operation 49
Other applicable documents 9
Overview (graphical) 31

P

Packaging and transport 39
Personnel
 Qualified personnel 18
Protective equipment 21

R

References 8

S

Safety 10
Safety devices and guards 14
Setup 45
Spare parts 65
Start-up 42

T

Tools 38
Troubleshooting table 60
Type plate 29

W

Warning notes 13
Warranty 9

14 List of figures

Fig. 1: Type plate (example)	29
Fig. 2: Operating principle and part throughput direction, left ejection direction.....	30
Fig. 3: Worm separator general overview	31
Fig. 4: Overview from the front	32
Fig. 5: Overview of the inlet side	33
Fig. 6: Side view with separating gap.....	33
Fig. 7: Control unit (left inlet side front view, right outlet side rear view).....	34
Fig. 8: Side view with separating gap.....	45
Fig. 9: MSL/MSR support.....	46
Fig. 10: SAL/SAR supporting frame.....	47
Fig. 11: Control unit	51
Fig. 12: Spare parts list: GL conveyor	65
Fig. 13: Exploded drawing of a worm separator	66
Fig. 14: PVC worm roller (standard) with motor	68
Fig. 15: Stainless-steel worm roller with motor	68
Fig. 16: MSL/MSR support.....	70
Fig. 17: SAL/SAR mounting frame	72

15 List of tables

Tab. 1: Abbreviations.....	7
Tab. 2: Units	7
Tab. 3: Qualification of the personnel	18
Tab. 4: Technical data.....	28
Tab. 5: Type plate descriptions.....	29
Table 1 - Maintenance plan.....	56
Tab. 2: Spare parts, worm separator	67
Tab. 3: Worm roller spare parts	69
Tab. 4: Spare parts, MSL/MSR support	71
Tab. 5: Spare parts SAL/SAR mounting frame.....	72

16 Appendix

This space is reserved for your notes: